

Demeyere

GROUP

MEUBLES DEMEYERE

178 à 184 rue de la Prévôté

BP 49

59840 PERENCHIES

FRANCE

SAV
SPAREPARTS
KUNDENDIENST
POS VENTAS
SERVICE NA VERKOOP
SERVIZIO POST-VENDITA
SERVICO DEPOIS DE VENDA
SERWIS POGWARANCY JNY
POPRODEJNÍ SERVIS
ÉRTÉKESÍTÉS UTÁNI SZOLGÁLTATÁS
SERVICIU POST-VÂNZARE
ПОСЛЕПРОДАЖНОЕ ОБСЛУЖИВАНИЕ
POPREDAJNÝ SERVIS
SATIŞ SONRASI HİZMET

346 160 - 00
LODGE BED

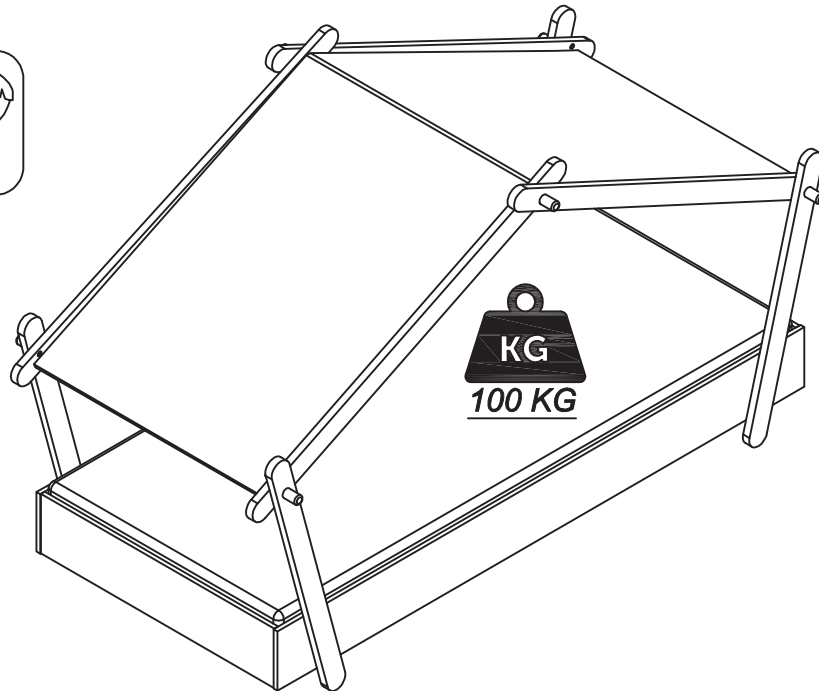

4H 00MN



(FR) SECURITE

RESPECTER LES INSTRUCTIONS DE MONTAGE DECRITES DANS LA NOTICE.
CE LIT N'EST PAS UN JOUET. NE LAISSEZ PAS UN ENFANT ESCALADER LA STRUCTURE AU DESSUS DU COUCHAGE.

(EN) CAUTION

FOLLOW CAREFULLY THE ASSEMBLY INSTRUCTIONS DESCRIBED IN THE DIRECTION
BED NOT TO BE USED AS A GAME. DO NOT ALLOW THE CHILDREN TO CLIMB ONTO THE ROOF OF THE BED.

(DE) SICHERHEITSVORSCHRIFTEN

BEACHTEN SIE BITTE UNBEDING DIE ANGEgebenEN AUFBAUVORSCHRIFTEN
NICHT ALS SPIELGERÄT ZU VERWENDEN. LASSEN SIE DIE KINDER NICHT AUF DAS DACH DES BETTES STEIGEN.

(ES) SEGURIDAD

RESPECTAR LAS INSTRUCCIONES DE MONTAJE DESCRIBIDAS EN EL FOLLETO
ESTA CAMA NO ES UN JUEGO. NO DEJAD UN NIÑO SUBIR POR ENCIMA DE LA ESTRUCTURA DE LA CAMA.

(NL) VEILIGHEID

DE IN DE GEBRUIKSAANWIJZING BESCHREVEN INSTRUCTIE RESPECTEREN
HET BED IS GEEN SPEELGOED. KINDEREN MOGEN NIET OP HET DAK VAN HET BED KLIMMEN.

(IT) SICUREZZA

RISPETTARE LE ISTRUZIONI DI MONTAGGIO DESCRITTE NEEL'AVVERTENZA
QUESTO LETTO NON È UN GIOCATTOLO. NON LASCIATE UN BAMBINO SCALARE LA STRUTTURA SOPRA IL LETTO.

(PT) SEGURANCA

RESPEITAR AS INSTURAS ÇOS DE MONTAGEH DESCRÉVEDAS NA INSTRU ÇÕES DE USO
ESTA CAMA NÃO É UM JOGO. NÃO DEIXEM UMA CRIANÇA ESCALAR A ESTRUTURA EM CIMA DA DORMIDA.

(PL) UWAGA

PROSZE PRZESTRZEGAĆ INTRUCJI MONTAŻU
TO ŁÓŻKO NIE JEST ZABAWKĄ. NIE POZWÓL, ABY DZIECKO WSPIĘŁO SIĘ NA STRUKTURĘ NAD ŁÓŻKIEM

(CS) BEZPEČNOST

DODRŽUJTE MONTÁŽNÍ POKYNY UVEDENÉ V NÁVODU.
NEHRAJTE SI NA STŘEŠE LŮŽKA.

(HU) Biztonság

KÖVESSE AZ ÚTMUTATÓBAN LEÍRT ÖSSZESZERELÉSI UTASÍTÁSOKAT.
NE JÁTSZSON AZ ÁGY TETEJÉN.

(RO) Siguranță

RESPECTAȚI INSTRUCȚIUNILE DE MONTARE DESCRISE ÎN MANUAL.
NU VĂ JUCAȚI PE ACOPERIȘUL PATULUI.

(RU) Безопасность

СЛЕДУЙТЕ УКАЗАНИЯМ ПО СБОРКЕ, ОПИСАННЫМ В ИНСТРУКЦИИ.
НЕ ИГРАЙТЕ НА КРЫШЕ КРОВАТИ.

(SK) Bezpečnosť

POSTUPUJTE PODĽA MONTÁŽNYCH POKYNOV UVEDENÝCH V NÁVODEI
NEHRAJTE SA NA STRIEŠKE POSTELE.

(TR) Güvenlik

KILAVUZDA BELİRTİLEN MONTAJ TALİMATLARINA UYUN.
YATAĞIN ÇATISI ÜZERİNDE OYUN OYNAMAYIN



MADE IN VIET NAM

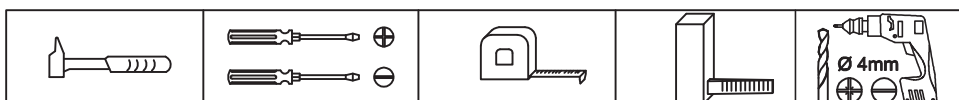

Français :

- Notice à conserver.
- En cours du montage, prenez garde aux risques de pincement et de cisaillement.
- Ne pas mettre le lit à proximité d'une source de chaleur.
- Ne pas s'asseoir à plusieurs sur le lit.
- Ne pas sauter sur le lit.
- Stocker le lit dans un endroit sec.
- Ne convient pas à un enfant de moins de 6 ans.
- Les meubles contenant des panneaux à base de bois (panneaux de particules, panneaux de fibres, contreplaqué...) peuvent émettre des substances polluantes dans l'air intérieur . Il est ainsi recommandé , après l'installation du meuble dans son logement, d'aérer fréquemment la pièce concernée pendant au moins quatre semaines afin de réduire son exposition aux polluants émis par le meuble.*

English :

- Retain the instructions for future reference.
- During the assembly, beware the risks of pinching and shearing.
- Keep the product away from heat sources.
- Do not sit on the bed several.
- Do not jump on the bed.
- Store the bed in a dry place.
- Not suitable for children under 6 years old.

Deutsch :

- Notiz zum Aufbewahren.
- Während der Montage bitte darauf achten sich nicht zu schneiden oder einzuklemmen das Bett nicht zu Nahe an einen Heizkörper stellen.
- Sich nicht gleichzeitig zu mehreren auf das Bett setzen.
- Nicht springen auf dem Bett.
- Das Bett an einem trockenen Platz aufbewahren.
- Nicht geeignet für Kinder unter 6 Jahren.

Español :

- Aviso .
- Durante el montaje, tenga cuidado con los riesgos de aplastamiento y cizallamiento.
- Fuente de fuego.
- No sentarse varias personas en la cama.
- No salte en la cama.
- Poner la cama en un lugar seco.
- No apto para niños menores de 6 años.

Nederlands :

- Bewaar deze instructie goed.
- Tijdens de montage, vermijd persen en drukken.
- Het bed niet naast een verwarmingsbron plaatsen.
- Niet met meerdere personen op het bed zitten.
- Niet op het bed springen.
- Het bed in een droge plaats bewaren.

Italy:

- Conservare le istruzioni per riferimenti futuri.
- Durante l'assemblea, attenzione i rischi di schiacciamento e di taglio.
- Tenere il prodotto lontano da fonti di calore .
- Non sedersi sul letto parecchi.
- Non saltare sul letto.
- Conservare il letto in un luogo asciutto.
- Non adatto a bambini sotto i 6 anni.

Poland :

- zachowaj instrukcję na przyszłość.
- Podczas montażu uważaj ryzyko zaciskające i ścinające.
- Produkt należy trzymać z dala od źródeł ciepła.
- Nie siadać na łóżku kilka.
- Nie skacz na łóżku.
- Łóżko przechowywać w suchym miejscu.
- Nie nadaje się dla dzieci poniżej 6 roku życia.

Portugal :

- Guarde as instruções para referência futura.*
- Durante a montagem, tenha cuidado com os riscos de beliscadura e de corte.*
- Mantenha o produto longe de fontes de calor.*
- Não se sentar na cama vários.*
- Não pule na cama.*
- Guarde a cama em um local seco.*
- Não recomendado para crianças menores de 6 anos de idade.*

Čeština:

- Návod si uschovejte.
- Během montáže dávejte pozor na nebezpečí přiskřípnutí a pořezání. Lůžko neumistujte do blízkosti zdroje tepla.
- Na lůžko nesedejte ve více osobách.
- Na lůžko neskákejte.
- Lůžko skladujte na suchém místě.
- Nevhodné pro děti mladší 6 let.

Magyar:

- Tartsa be az utasítást
- Az összeszerelés során vigyázzon a becsípődés és a vágás veszélyeire.
- Ne helyezze az ágyat hőforrás közelébe.
- Ne üljön az ágyra.
- Ne ugorjon az ágyra.
- Az ágyat száraz helyen tárolja.
- Nem alkalmas 6 év alatti gyermek számára.

Română:

- Manual de păstrat
- În cursul montării, aveți grijă la riscurile de ciupire și de tăiere.
- Nu amplasați patul în apropiere de o sursă de căldură.
- Nu vă așezați mai multe persoane pe pat.
- Nu săriți pe pat.
- Depozitați patul într-un loc uscat.
- Nu se recomandă copiilor mai mici de 6 ani.

Русский:

- Важная информация
- При сборке остерегайтесь риска защемления пальцев и порезов.
- Не ставьте кровать рядом с источником тепла.
- Нельзя сидеть на кровати более чем одному человеку.
- Не прыгайте на кровати.
- Храните кровать в сухом месте.
- Не используйте для детей младше 6 лет.

Slovenský:







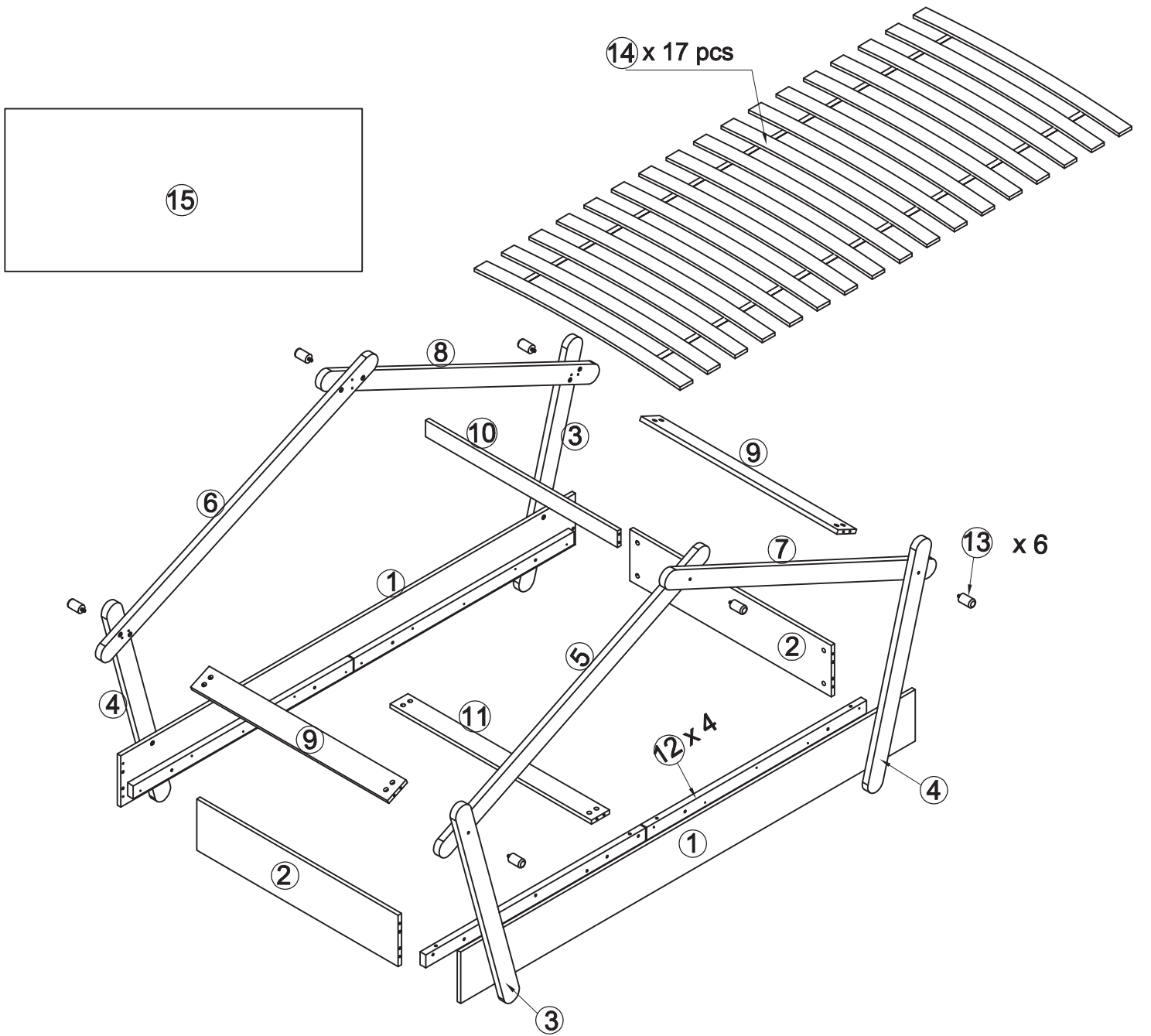

- Návod si starostlivo uschovajte.
- Pri montáži si dávajte pozor na nebezpečenstvo pricviknutia a strihu.
- Posteľ neumiestňujte do blízkosti zdroja tepla.
- Na posteľ si nesmie sadieť viacero osôb súčasne.
- Na posteli neskáčte.
- Posteľ uskladnite na suchom mieste.
- Nevhodné pre deti mladšie ako 6 roky.

Türk:

- Kılavuzu saklayın
- Montaj sırasında sıkışma ve kesilme ile yaralanma tehlikelerine karşı dikkatli olun
- Yatağı bir ısı kaynağı yakınına yerleştirmeyin
- Yatak üzerine birden fazla kişi oturmamalıdır
- Yatak üzerinde zıplamayın
- Yatağı kuru bir ortamda muhafaza edin
- 6 yaş altı çocuklar için uygun değildir



REF	Dimension (mm)	Qt'y	REF	Dimension (mm)	Qt'y	REF	Dimension (mm)	Qt'y
1	2036*199*15	1	6	1350*70*25	1	11	902*80*15	1
2	902*199*15	1	7	1350*70*25	1	12	985*50*15	4
3	900*70*25	2	8	1350*70*25	1	13	Ø30*50	6
4	900*70*25	2	9	882*92*15	2	14	900*55*12	17
5	1350*70*25	1	10	859*64*15	1	15	Fabric	1

ITEM	HARDWARE	DESCRIPTION	Q'TY
A		Ø6 x 20 mm	8 PCS
B		Ø8 x 30mm	28 PCS
C		TF Ø4 x 25 mm	20 PCS
D		Ø14.5 x 11.9 mm	24 PCS
E		Ø5 x 45 mm	24 PCS
F		Ø3x14 mm	8 PCS
G		30x15x2 mm	4 PCS
H		Ø6x30mm	12 PCS

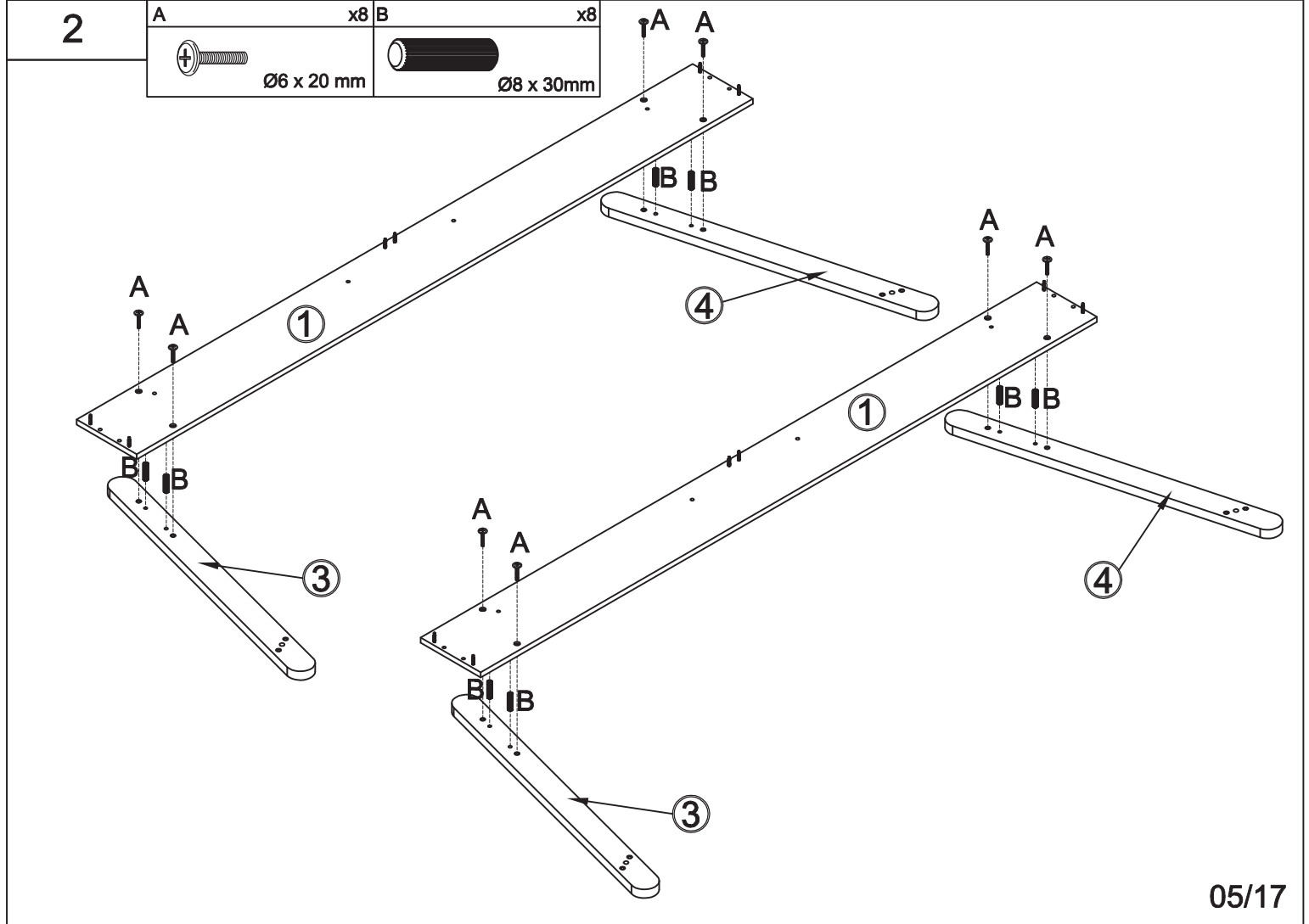
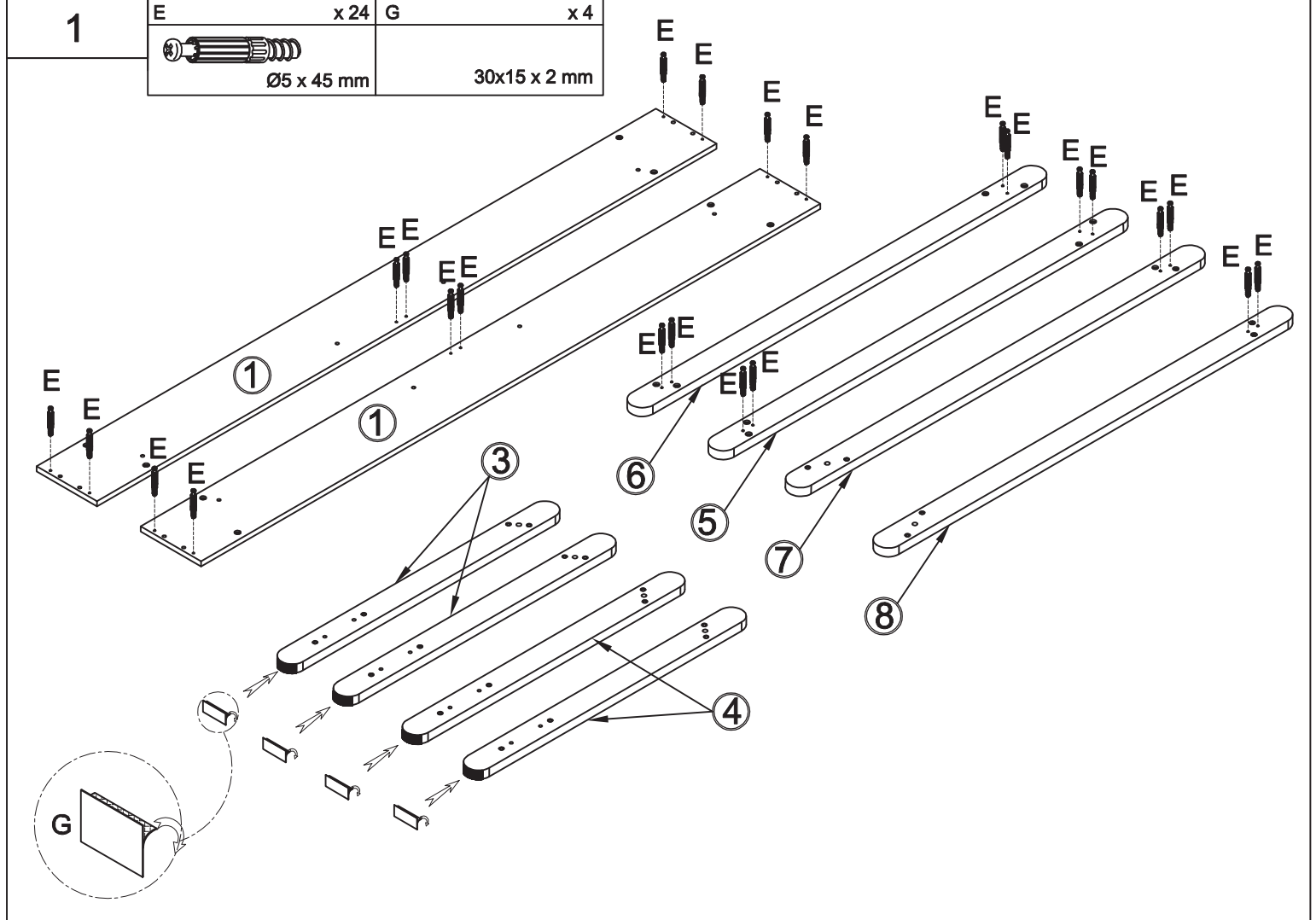

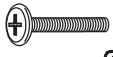

3

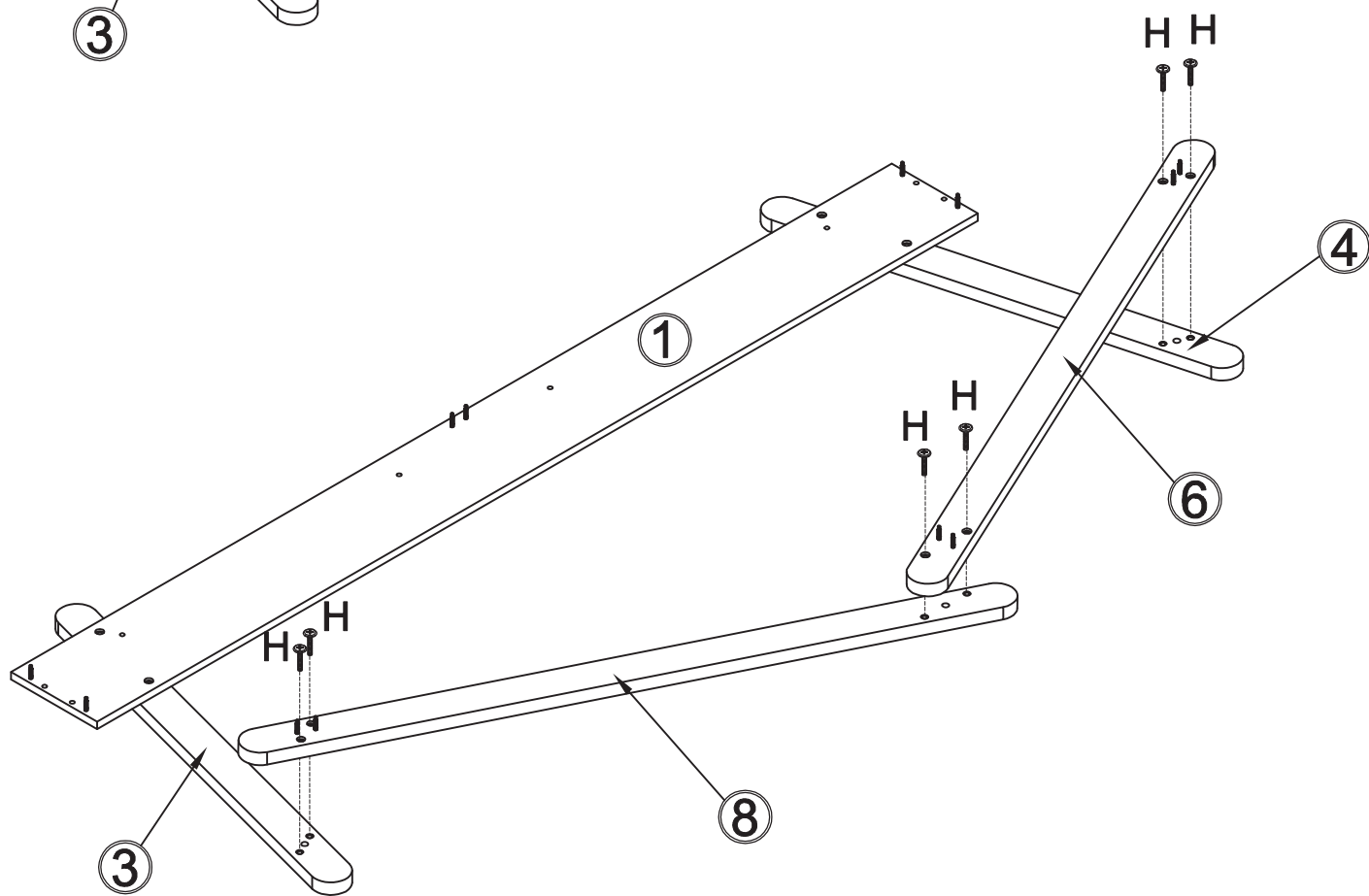
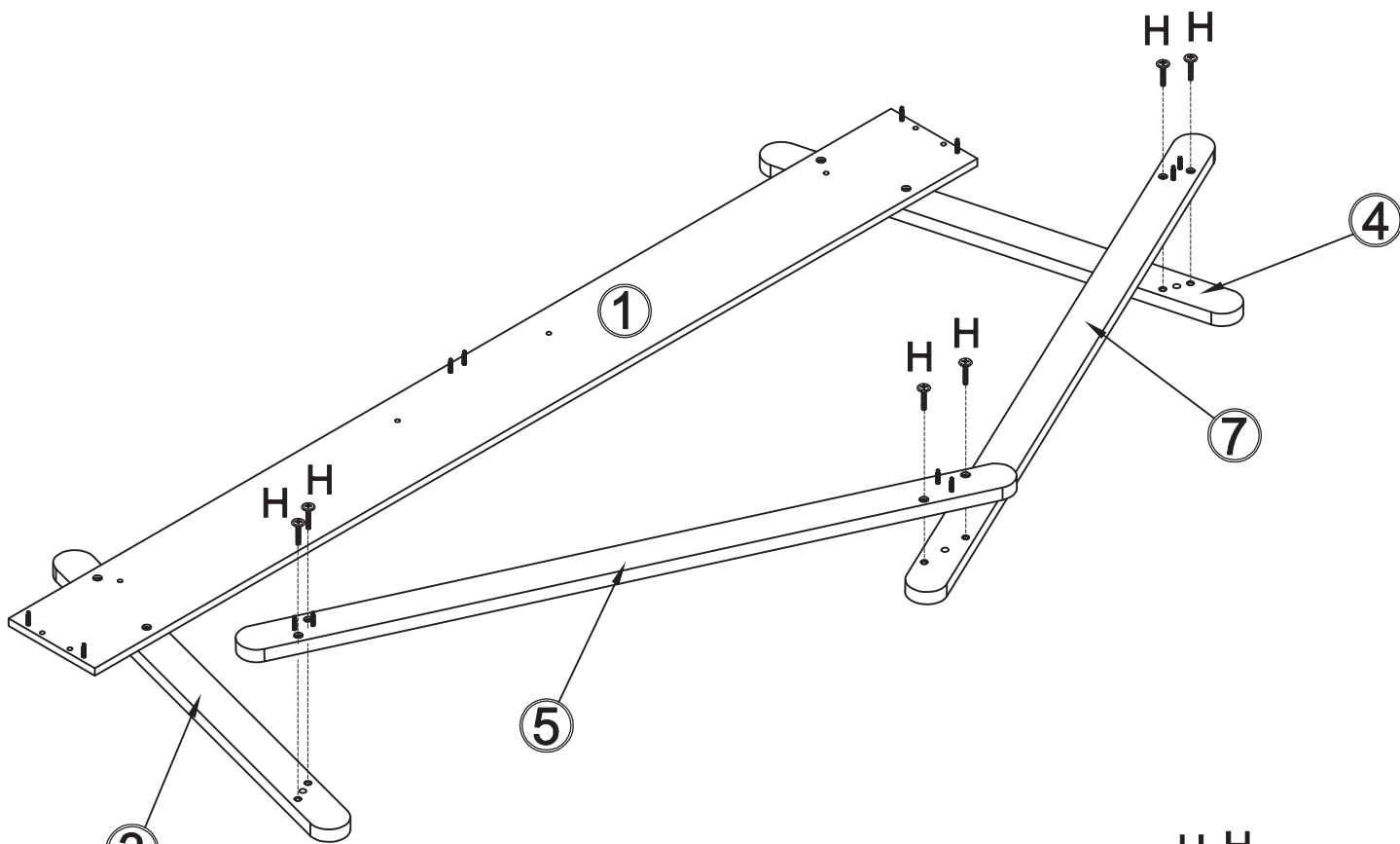
H	x12
	
Ø6 x 30 mm	



4

B	x4	D	x4
			
Ø8 x 30mm		Ø14.5 x 11.9 mm	

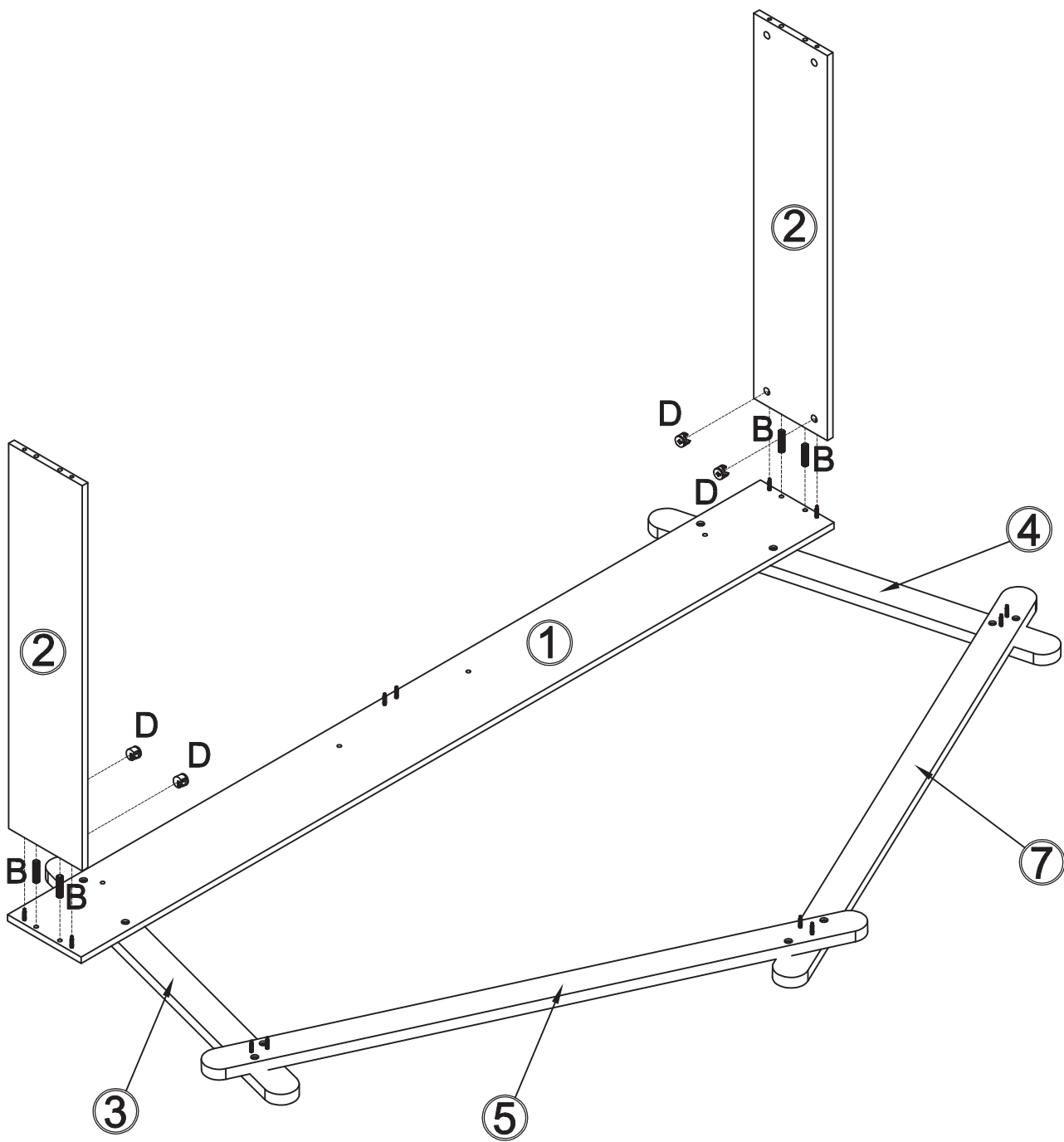

5

D x6



Ø14.5 x 11.9 mm

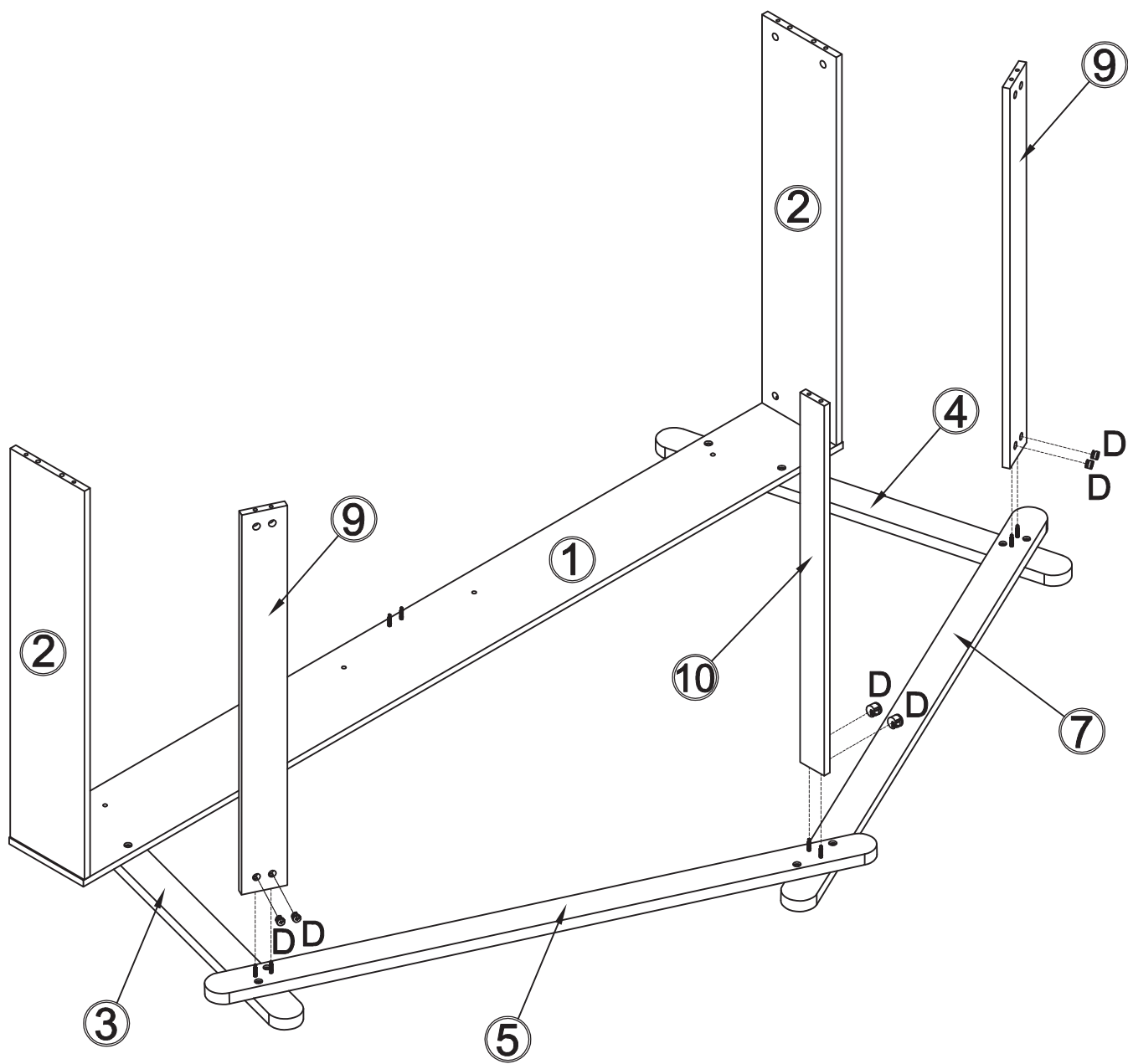

6

D



x2

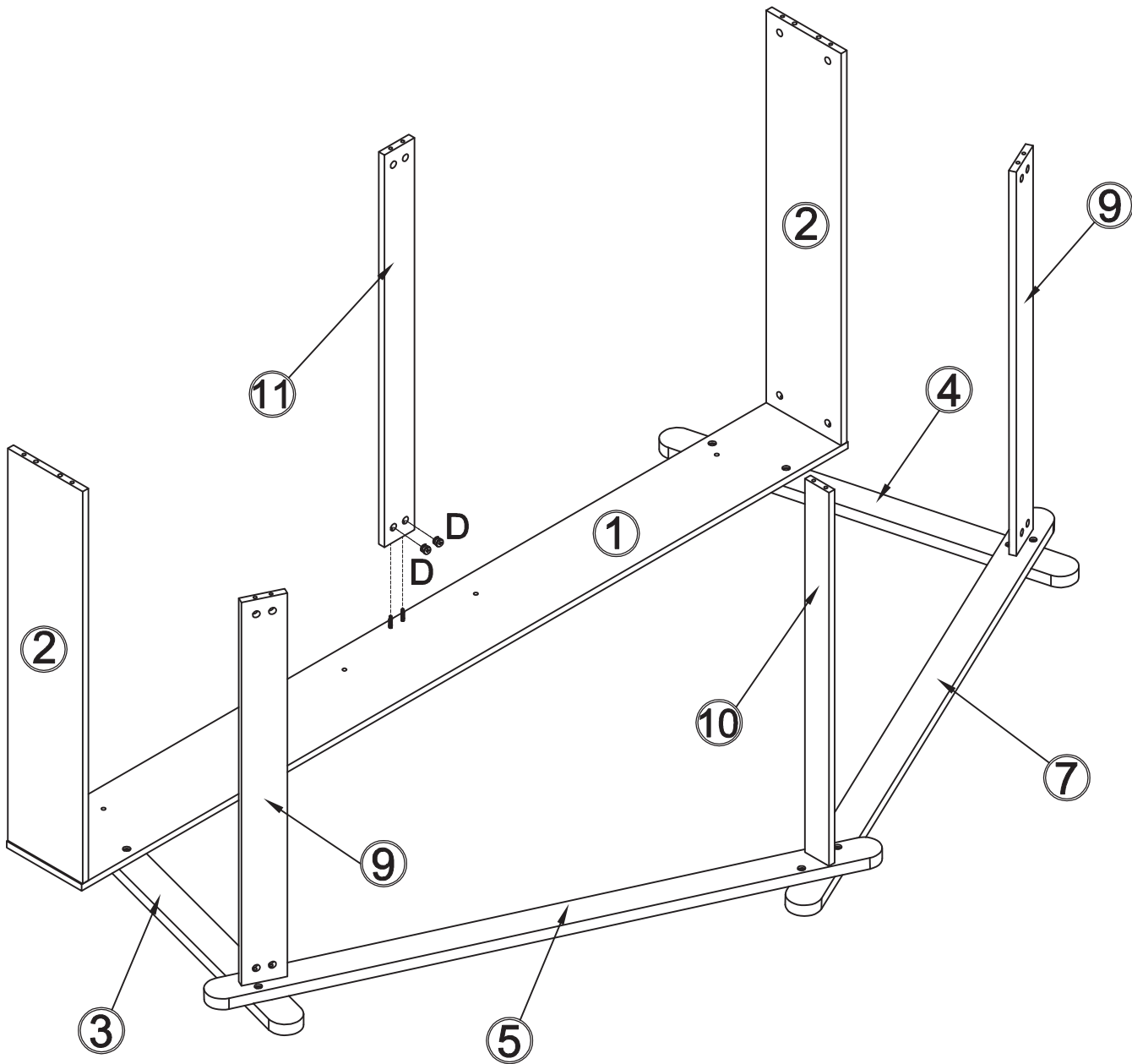

Ø14.5 x 11.9 mm



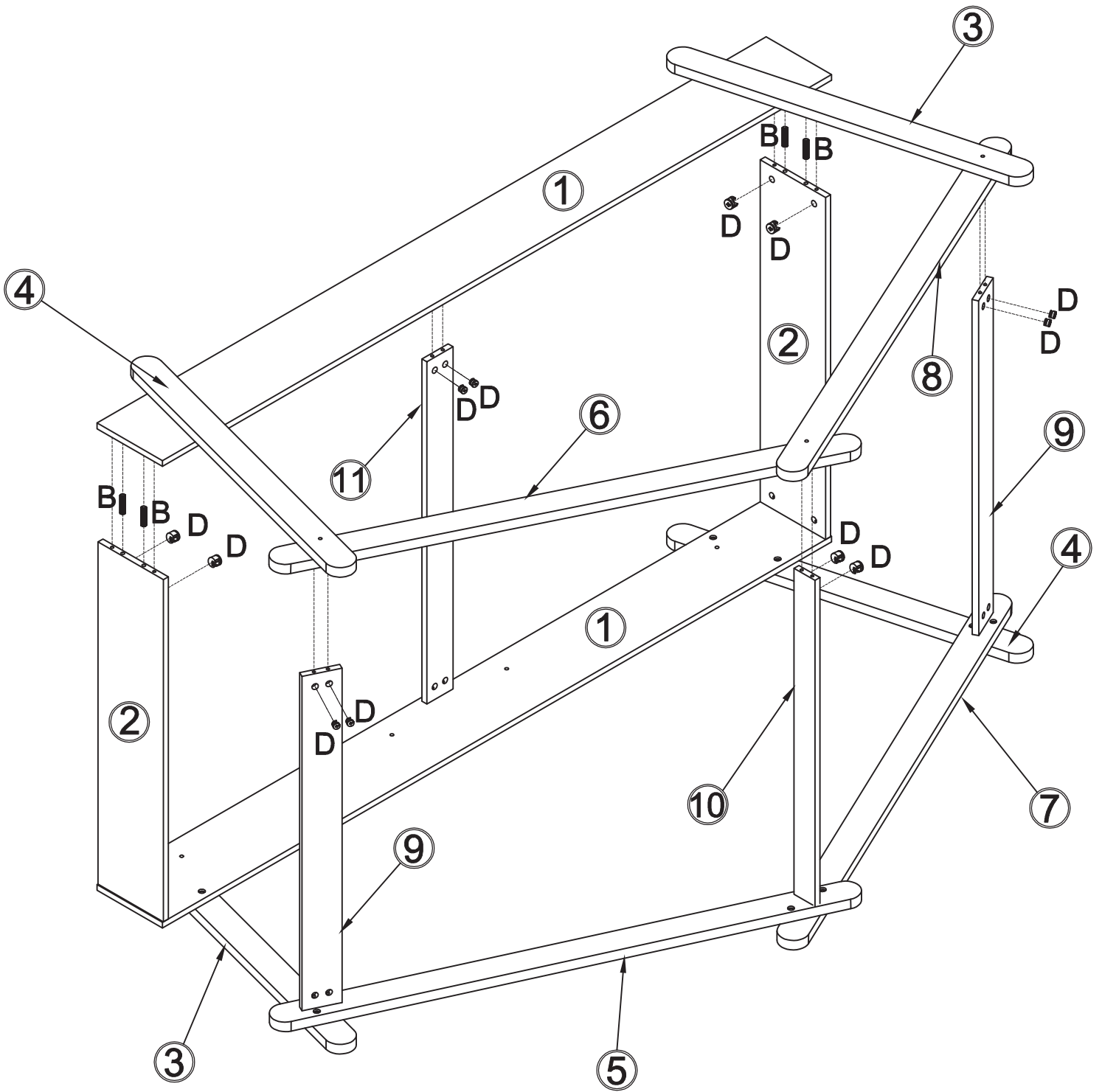

7

B	x4 D	x12
		
Ø8 x 30mm	Ø14.5 x 11.9 mm	



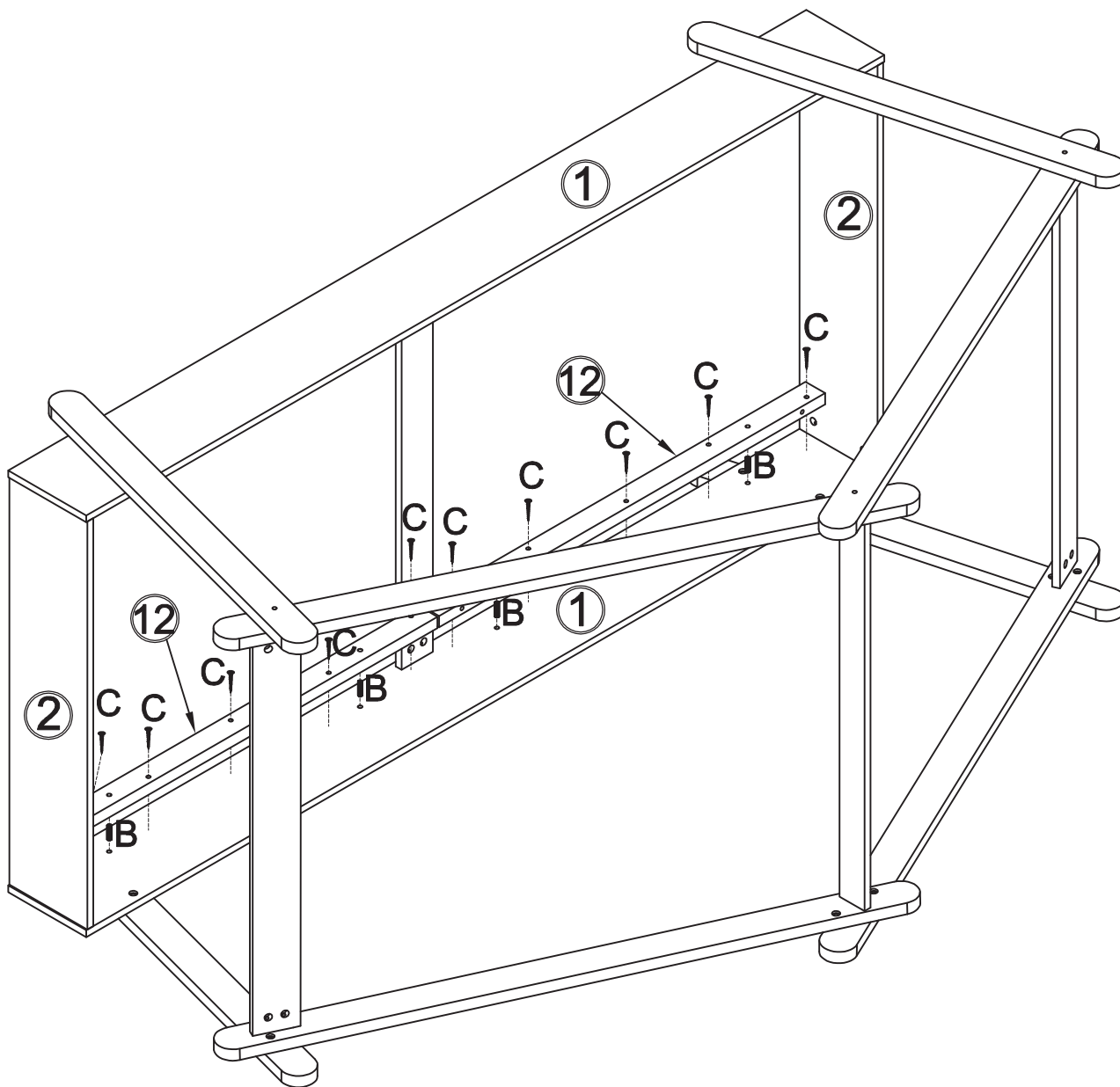

8

B	x4 C	x10
		
Ø8 x 30mm	TF Ø4 x 25 mm	



9

B	x4	C	x10
			
Ø8 x 30mm		TF Ø4 x 25 mm	

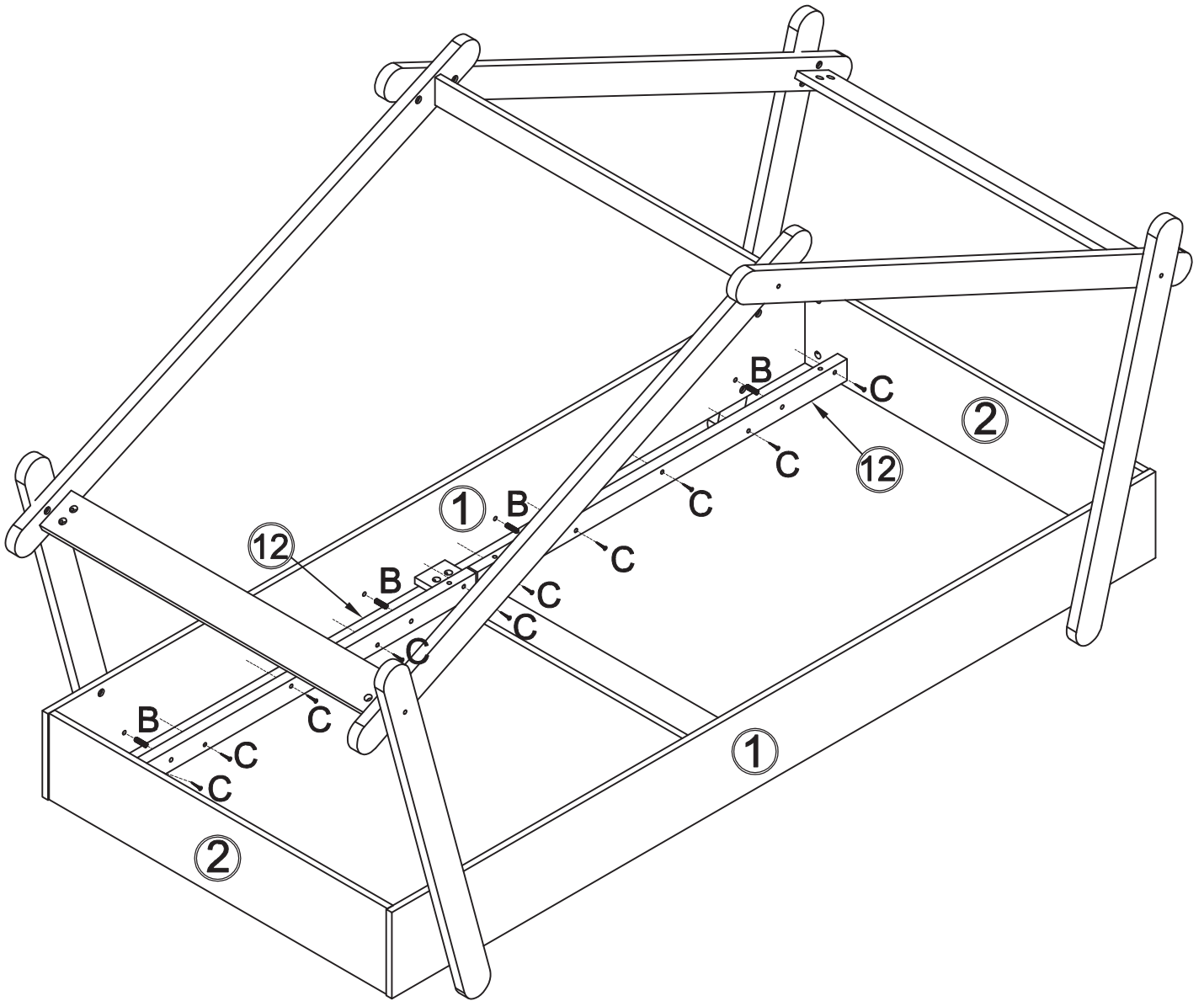

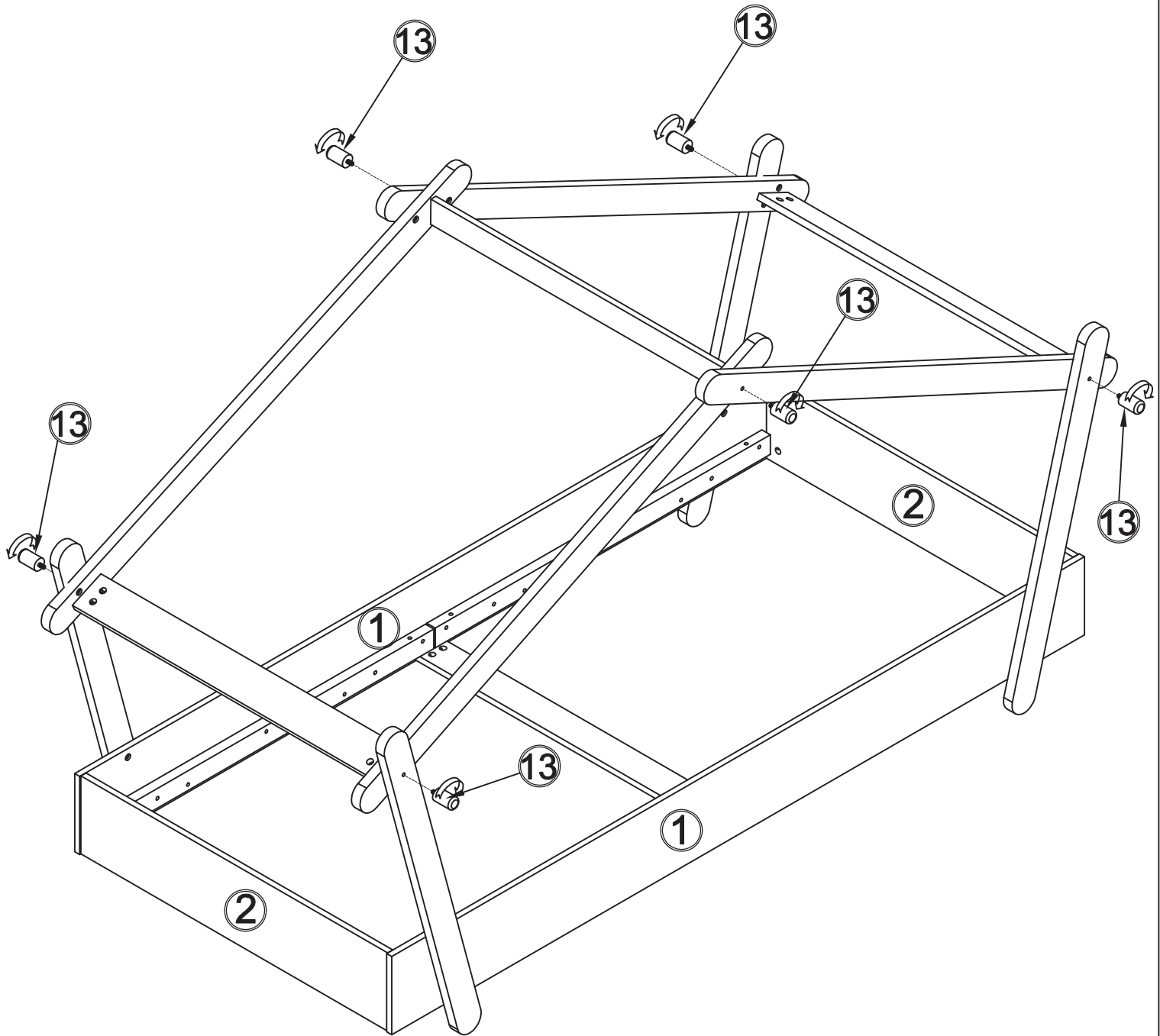

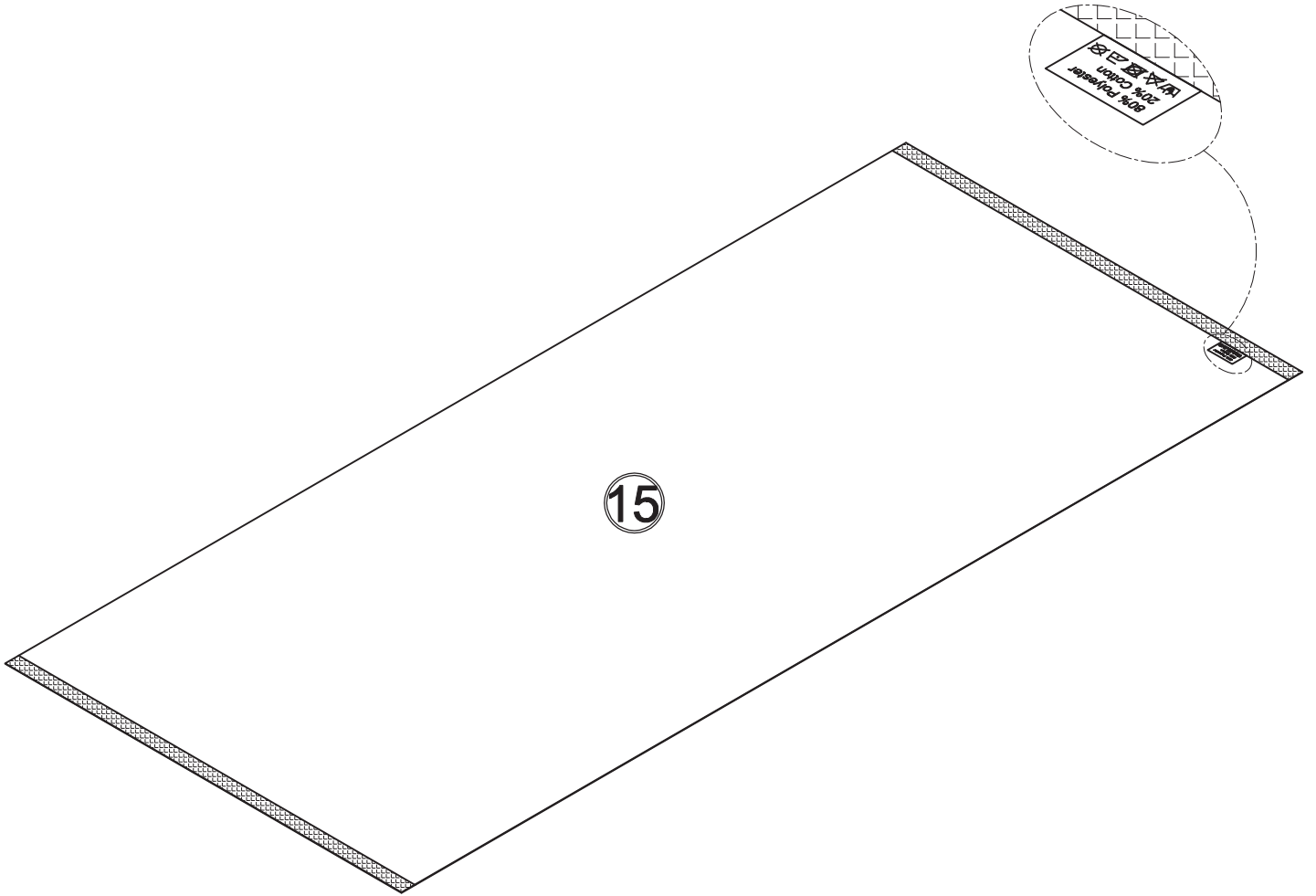

12



1

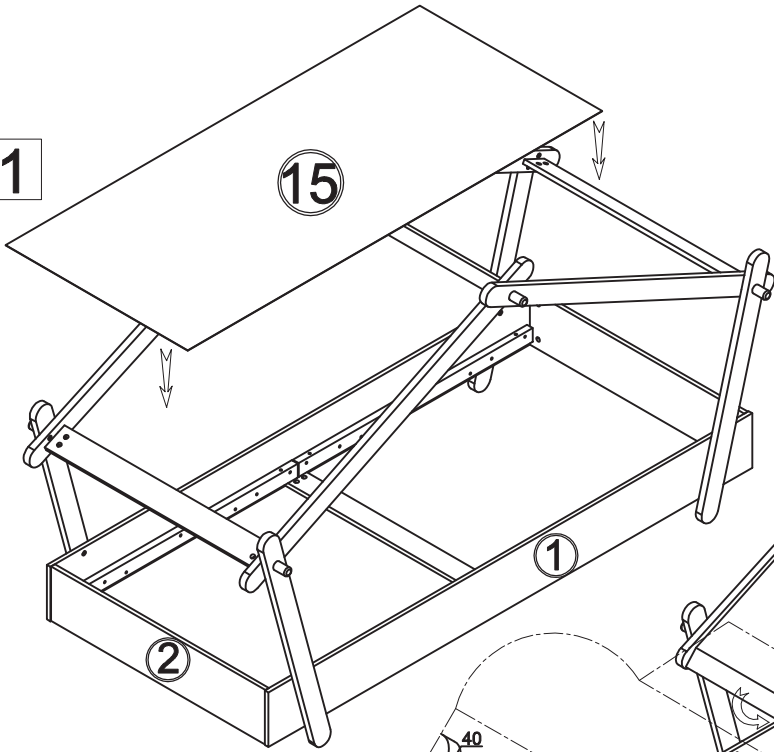

2

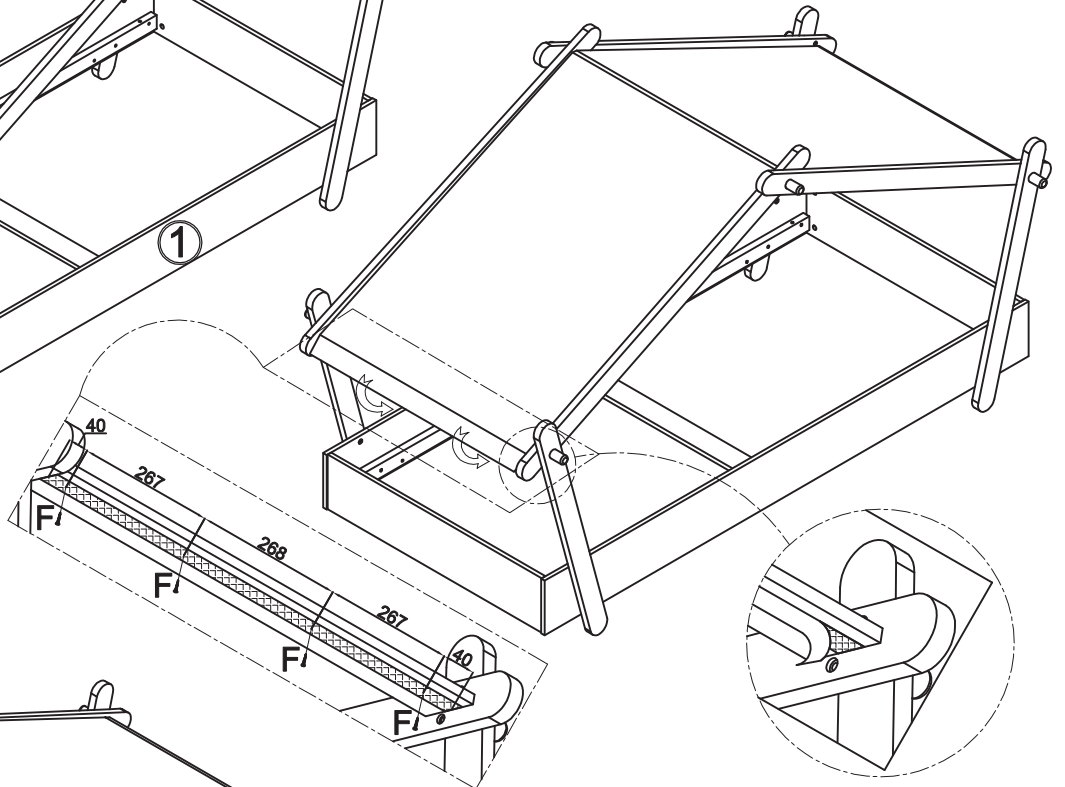

3

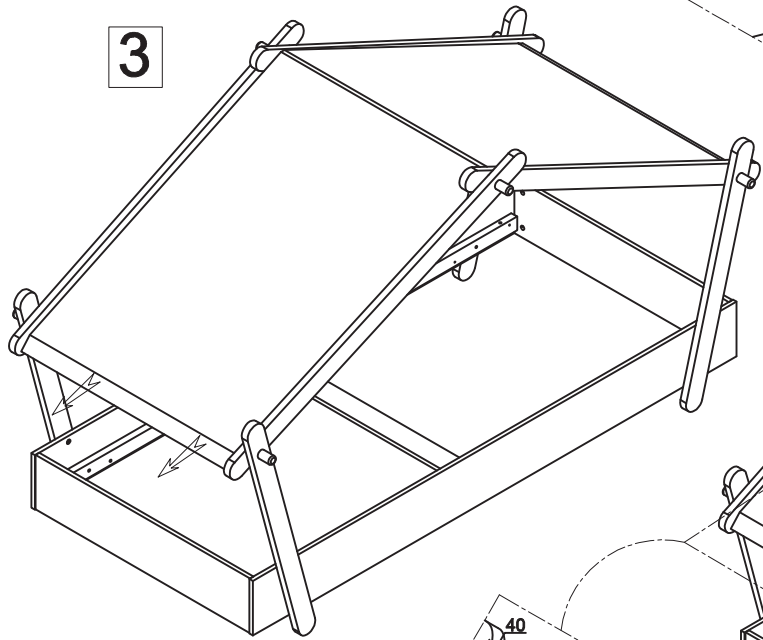

4

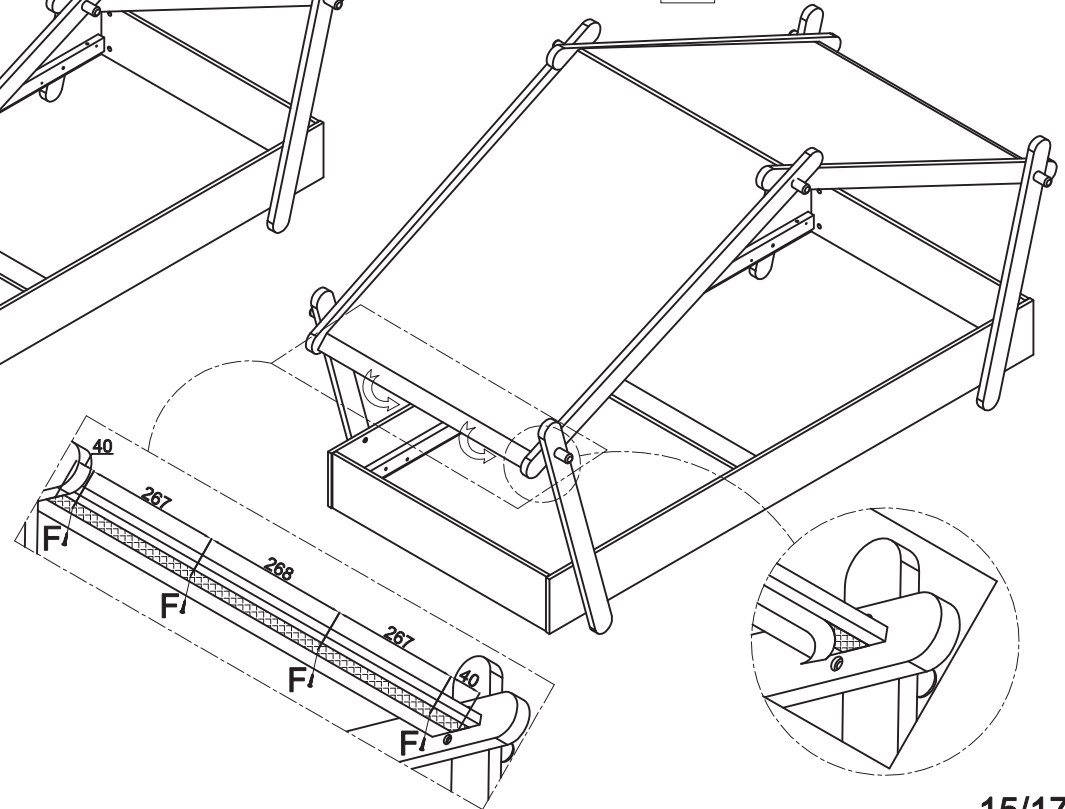

B x4
Ø8 x 30mm

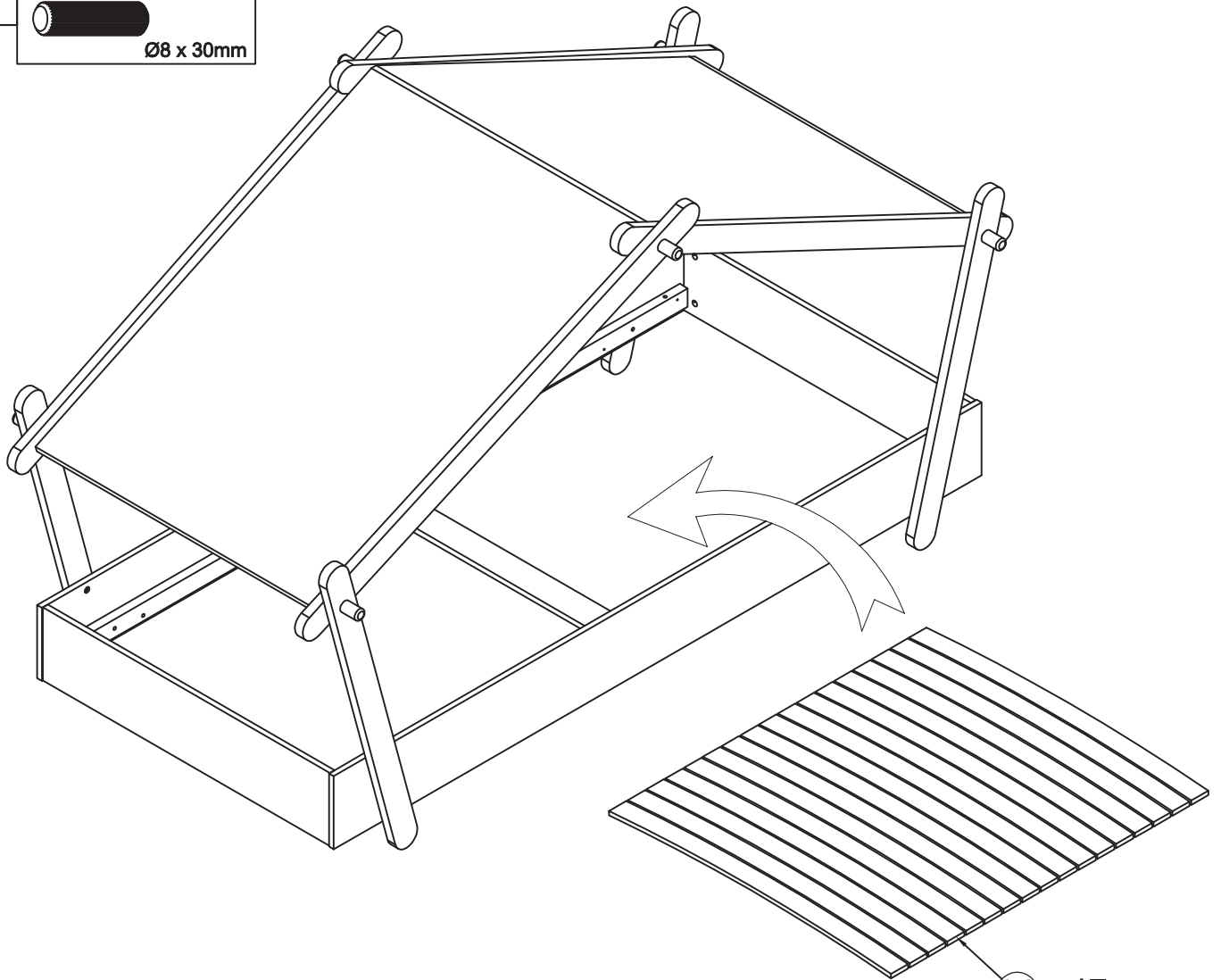

14 x 17 pcs

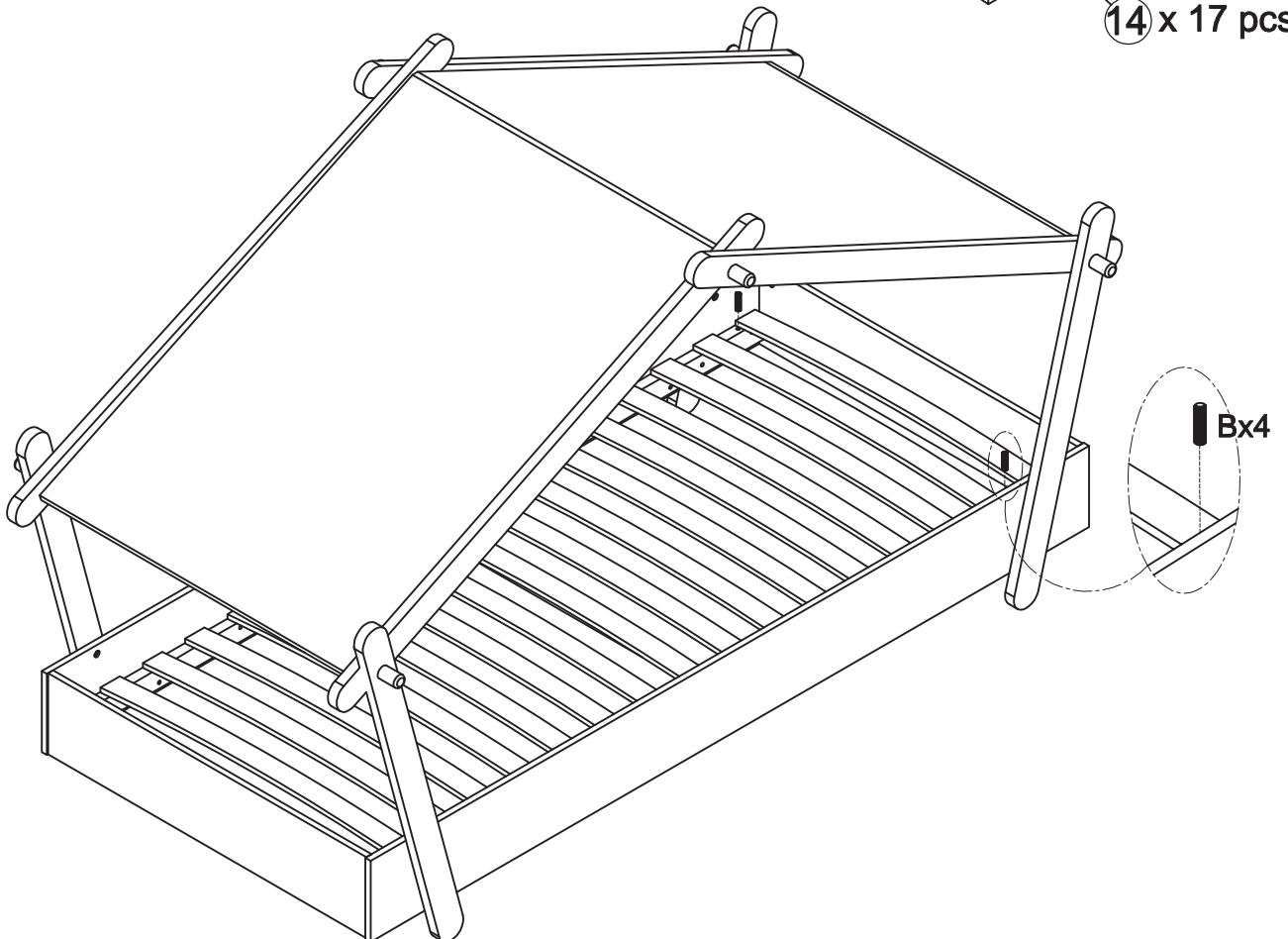

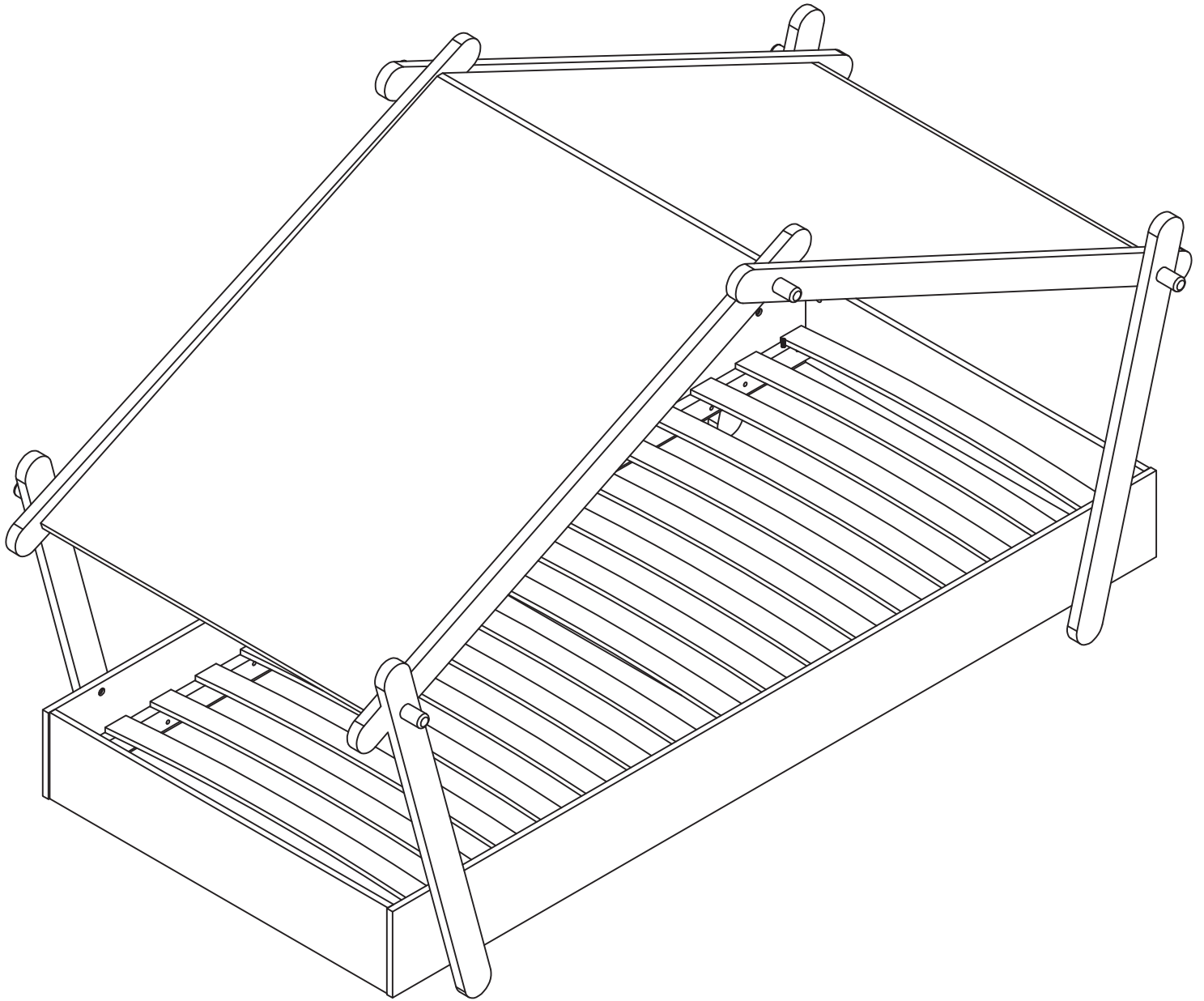

Info tri déchets

www.quefairedemesdechets.fr