

Istruzioni per il montaggio base sottolavello SOFT 80

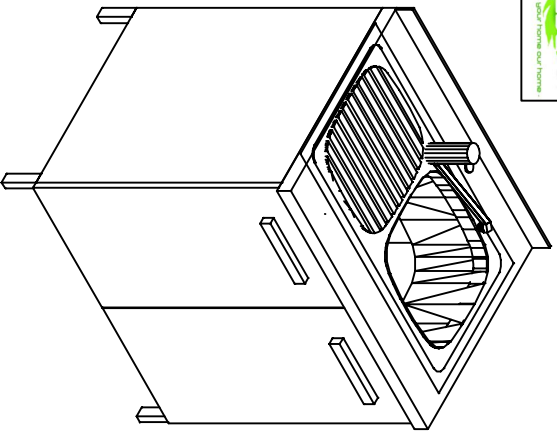

Ferramenta: Birone legno q.tà n°10 Bussola q.tà n°12 Tirante q.tà n°12 Eccentrico q.tà n°12 Vite x maniglie q.tà n°4 Vite x piedini q.tà n°12		Componentistica: Cerniera q.tà n°4 Basetta q.tà n°4 Maniglia cromata n°2 Piedini n°4 Cosa serve: 	
--	--	--	--

Mantenzione:
Pulisci con un panno umido e un detergente poco concentrato. Asciuga con un panno.

2

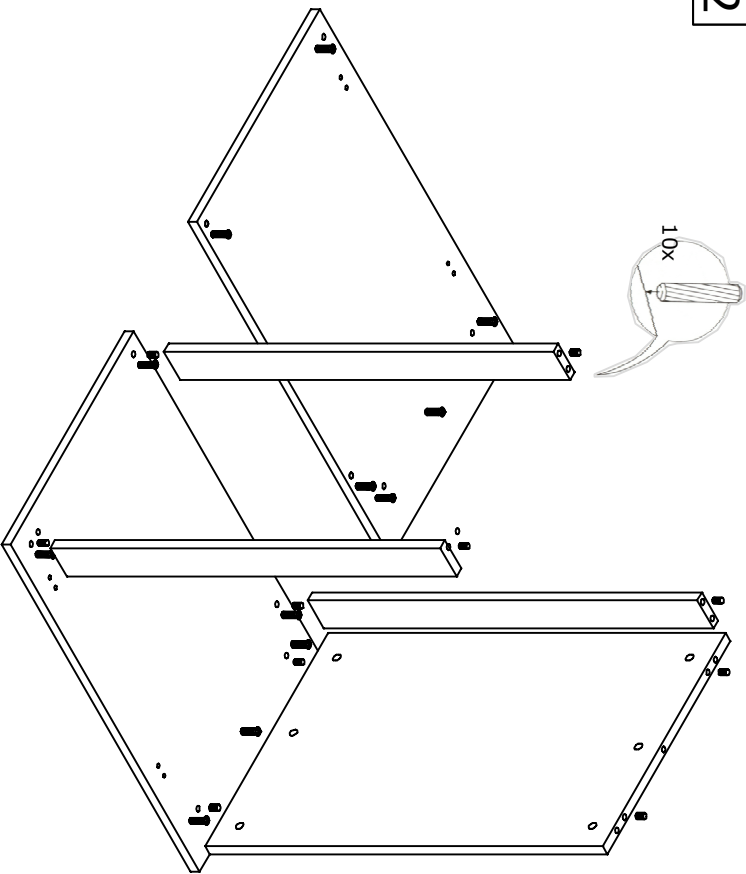

1

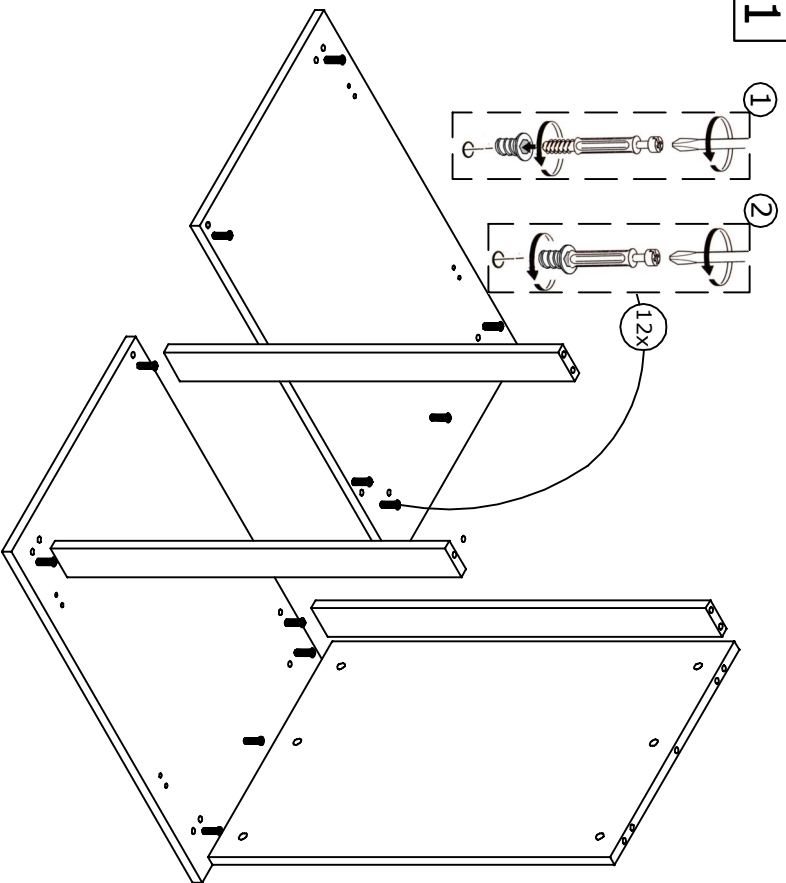

3

