

**HYUNDAI**  
POWER PRODUCTS

# MOTOSEGHE DA POTATURA COD. 35520 MOD. TCS2510

**MANUALE D'USO E MANUTENZIONE - ISTRUZIONI ORIGINALI**

**Leggere attentamente il manuale di istruzioni prima di utilizzare il prodotto. Conservare per consultazioni future.**

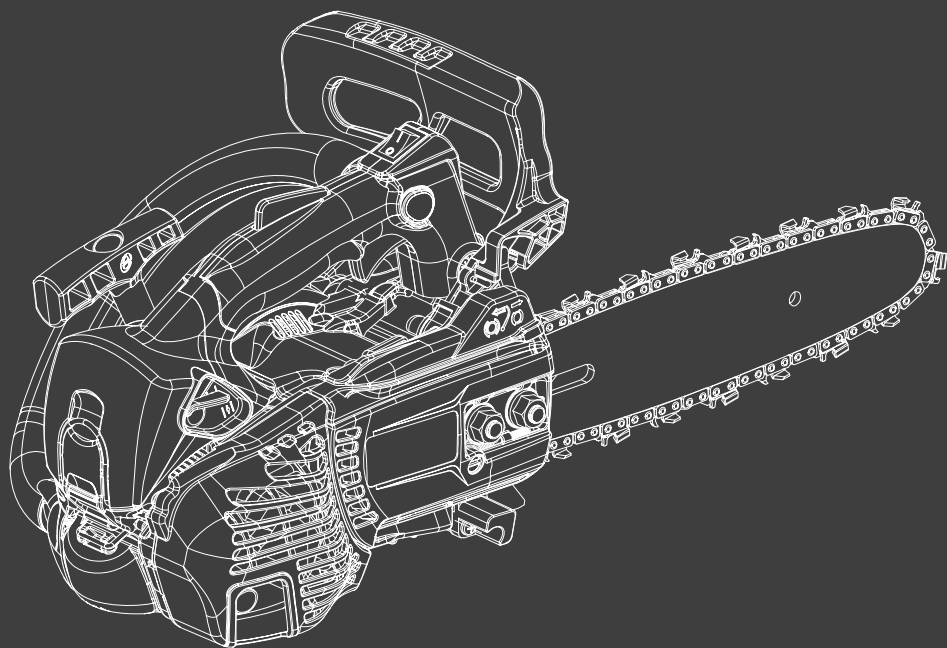

**HYUNDAI**  
POWER PRODUCTS



Gentile Cliente,

grazie per avere scelto un prodotto Hyundai Power Products, distribuito in Italia da Vinco Srl.

I nostri prodotti sono costruiti con i più elevati standard qualitativi per permettere una esperienza di uso semplice, piacevole e sicura.

Sia che i nostri prodotti vengano utilizzati per i tuoi hobby, sia in modo più frequente, ti preghiamo di spendere qualche momento nella lettura di questo libretto di istruzioni.

Le informazioni che seguono sono molto importanti per la sicurezza e per ottenere il meglio dal prodotto.

In caso di necessità, per qualsiasi chiarimento o consiglio, siamo a disposizione ai recapiti riportati in fondo a questo libretto: saremo felici di aiutare e risolvere qualsiasi genere di problema grazie ai nostri tecnici specializzati.

Grazie per la preferenza!

Vinco Srl  
Licenziatario ufficiale Italia  
Hyundai Power Products

# SONO ARRIVATE LE VIDEO ISTRUZIONI SEGUICI SUL NOSTRO CANALE YOUTUBE!

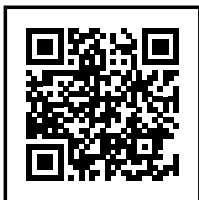

**SCANSIONA IL QR CODE PER VISITARE SUBITO IL NOSTRO CANALE  
OPPURE CERCA HYUNDAI ITALIA, VINCO E POLAR SU YOUTUBE**

I nostri tecnici ti accompagneranno nella risoluzione delle problematiche più comuni sui nostri prodotti. Rispondiamo alle vostre domande e a creiamo nuovi contenuti per rispondere alle vostre esigenze.

**HAI UN PROBLEMA E NON TROVI IL VIDEO CHE LO RISOLVA?  
ISCRIVITI E COMMENTA PER RICHIEDERE NUOVE VIDEO ISTRUZIONI,  
E CI IMPEGNEREMO A CREARLE PER TE!**

The screenshot shows the YouTube channel page for "HYUNDAI Italia, VINCO e POLAR". The channel has 305 subscribers and is currently on the "PLAYLIST" tab. The main banner features the text "IL TECNICO RISPONDE" over an image of a technician. Below the banner, there are four featured playlists: "GENERATORI INVERTER" (12 videos), "DECESPUGLIATORI" (4 videos), "MOTOSEGHE" (11 videos), and "POTATORE A BATTERIA" (2 videos). The "Video caricati" section shows five recent uploads, including "CAMBIO OLIO E FILTRO IN 5 MINUTI generatore diesel", "COME RISOLVERE MOTOSEGA INGOLFATA", "GENERATORI FULLPOWER BENZINA E DIESEL...", "Soffiatore 2 Tempi Hyundai 35801 - UNBOXING...", and "Come richiedere assistenza, sostituzione del prodotto...". A second "DECESPUGLIATORI" section follows, featuring five more videos such as "4 MONTIAMO ACCESSORI PER MULTIFUNZIONE", "come regolare e fissare l'acceleratore di un...", "Montare e regolare correttamente la maniglia di...", "Aggianciare facilmente accessori decespugliatore...", and "DECESPUGLIATORE 35200 35220 GUIDA VIDEO...".

**IL TECNICO RISPONDE**

HYUNDAI Italia, VINCO e POLAR  
305 iscritti

HOME VIDEO **PLAYLIST** CANALI INFORMAZIONI

**GENERATORI INVERTER** 12  
HYUNDAI Italia, VINCO e POLAR  
VISUALIZZA LA PLAYLIST COMPLETA

**DECESPUGLIATORI** 4  
HYUNDAI Italia, VINCO e POLAR  
VISUALIZZA LA PLAYLIST COMPLETA

**MOTOSEGHE** 11  
HYUNDAI Italia, VINCO e POLAR  
VISUALIZZA LA PLAYLIST COMPLETA

**POTATORE A BATTERIA** 2  
HYUNDAI Italia, VINCO e POLAR  
VISUALIZZA LA PLAYLIST COMPLETA

Video caricati ▶ RIPRODUCI TUTTI

**CAMBIO OLIO E FILTRO IN 5 MINUTI generatore diesel** 5:56  
145 visualizzazioni • 1 mese fa  
Sottotitoli

**COME RISOLVERE MOTOSEGA INGOLFATA** 1:06  
1347 visualizzazioni • 1 mese fa  
Sottotitoli

**GENERATORI FULLPOWER BENZINA E DIESEL...** 3:56  
332 visualizzazioni • 3 mesi fa

**Soffiatore 2 Tempi Hyundai 35801 - UNBOXING...** 2:42  
85 visualizzazioni • 3 mesi fa  
Sottotitoli

**Come richiedere assistenza, sostituzione del prodotto a...** 1:04  
133 visualizzazioni • 3 mesi fa  
Sottotitoli

**DECESPUGLIATORI** ▶ RIPRODUCI TUTTI

**4 MONTIAMO ACCESSORI PER MULTIFUNZIONE** 6:30  
Decespugliatore multifunzione 4 in 1. Tutoria...  
HYUNDAI Italia, VINCO e POLAR

**come regolare e fissare l'acceleratore di un...** 1:31  
HYUNDAI Italia, VINCO e POLAR

**Montare e regolare correttamente la maniglia di...** 1:53  
HYUNDAI Italia, VINCO e POLAR

**Aggianciare facilmente accessori decespugliatore...** 3:57  
HYUNDAI Italia, VINCO e POLAR

**DECESPUGLIATORE 35200 35220 GUIDA VIDEO...** 2:05  
HYUNDAI Italia, VINCO e POLAR

## **ATTENZIONE: CONDIZIONI DI DECADENZA DELLA GARANZIA LEGALE LEGGERE PRIMA DI UTILIZZARE IL PRODOTTO**

Nel rispetto della normativa attuale circa le condizioni di garanzia, la copertura decade in caso di uso improprio o errata manutenzione.

Questo prodotto è stato realizzato rispettando tutti le normative ed è progettato per un utilizzo commisurato alla potenza del motore e della relativa componentistica.

Il Rivenditore Hyundai è a disposizione per qualsiasi chiarimento circa le prestazioni e le modalità d'uso del prodotto.

### **CONDIZIONI DI DECADENZA DELLA GARANZIA LEGALE**

#### **Superamento dei limiti di utilizzo.**

Il superamento volontario e reiterato dei limiti di utilizzo per negligenza o imperizia dell'utilizzatore può causare danni irreparabili alla motosega e alle sue componenti. Qualora ciò venga verificato tecnicamente dall'Assistenza, è causa di decadimento della garanzia.

A titolo esemplificativo, il continuo blocco delle operazioni di taglio dovuto all'utilizzo di errata tecnica può provocare surriscaldamento, blocco e rottura del motore.

**Utilizzo di carburanti non idonei.** Questa motosega è progettata per funzionare con carburanti per autotrazione civile miscelati con oli specifici per motori a 2 tempi. Verificare con attenzione il tipo di carburante indicato in questo libretto. In caso di utilizzo di carburanti diversi da quelli prescritti (a titolo esemplificativo e non esaustivo: biodiesel, olio di colza, etanolo e sue miscele, miscele per motori 2 tempi con oli non specifici) la garanzia decade. Utilizzare solo carburanti di qualità e privi di impurità venduti da operatori commerciali autorizzati alla vendita di carburanti per autotrazione. Si consiglia, per un utilizzo ottimale e per prolungare la vita del motore, l'uso di additivi per migliorare l'efficienza, la pulizia e la durata del motore. Seguire in questo caso le indicazioni del produttore degli additivi stessi.

**Mancata manutenzione ordinaria.** Consultare le indicazioni circa gli interventi di manutenzione periodica contenuti in questo manuale. In caso di rilevamento, da parte dell'Assistenza, di danni o malfunzionamenti derivanti da mancata manutenzione periodica la garanzia legale potrebbe decadere. A titolo esemplificativo e non esaustivo, interventi dell'Assistenza per mancati avvii della motosega, derivanti da candele sporche, carburanti deteriorati, oli bruciati o di qualità insufficiente non verranno coperti da garanzia e saranno quindi considerati interventi a pagamento.

**Utilizzo improprio.** Il prodotto deve essere utilizzato per operazioni di taglio di legno o materiali compositi in legno, che non diano effetti di riscaldamento o di emissione di sostanze pericolose durante il taglio. Controllare che le condizioni ambientali di lavoro siano conformi a quanto descritto in questo libretto. Il prodotto non deve essere utilizzato per tagliare materiali diversi dal legno, come (elenco non esaustivo, ma indicativo): metalli o materiali inerti come cemento, mattoni, ceramica.

**Modifiche non autorizzate.** Sono autorizzate le sole modifiche eventualmente concordate con l'Assistenza. Non sono considerate modifiche l'uso ricambi originali forniti direttamente dall'Assistenza e le operazioni di manutenzione ordinaria prescritte in questo manuale.

## ISTRUZIONI DI SICUREZZA

### ATTENZIONE: LEGGERE TUTTE LE INDICAZIONI QUI RIPORTATE PRIMA DELL'UTILIZZO DELLA MOTOSEGA

Questa motosega è progettata secondo i migliori criteri di sicurezza ed ergonomia disponibili, ma è necessario prestare la massima attenzione durante l'utilizzo.

La presenza di parti taglienti in movimento e di calore, unita all'uso di oli e carburanti e all'emissione di gas nocivi, rendono questo dispositivo potenzialmente pericoloso se non utilizzato propriamente.

**VERIFICARE L'INTEGRITÀ DELLA CONFEZIONE E DEL PRODOTTO.** Eventuali lesioni presenti sul prodotto o parti mancanti vanno immediatamente notificate al Rivenditore. Non utilizzare il prodotto fino a che non sia stata confermata la regolarità delle condizioni d'uso da parte del Rivenditore o del Servizio di Assistenza Vinco Srl – Hyundai Power Products.

**LEGGERE TUTTE LE ISTRUZIONI RIGUARDANTI LA PREPARAZIONE, L'UTILIZZO E LA MANUTENZIONE.** Un errato utilizzo di questo prodotto può provocare gravi lesioni e anche la morte.

• **AMBIENTE DI LAVORO.** L'ambiente di lavoro deve essere:

- **Luminoso** per poter controllare il lavoro. Non utilizzare in presenza di luci troppo soffuse, fumi, bassa luminosità ambientale.
- **Ventilato:** i gas di scarico sono tossici, la motosega non deve essere utilizzata in ambienti chiusi o privi di ventilazione.
- **Lontano da possibili fonti di incendio.** La benzina utilizzata nella miscela carburante e i suoi vapori sono altamente infiammabili. Tutte le operazioni di rifornimento di carburante e manutenzione vanno svolte lontano da possibili fonti di incendio quali fiamme libere, oggetti surriscaldati, fonti di scintille elettriche quali cavi scoperti, utensili che utilizzano corrente ad arco o piezoelettrici.
- **Spazioso.** I movimenti non devono essere impediti e deve esserci la possibilità di manovrare liberamente la motosega in caso di emergenza. Non operare in ambienti angusti o che blocchino i movimenti.
- **Sicuro.** Se è necessario lavorare su supporti o sostegni posti ad una certa altezza da terra, questi devono garantire la sicurezza dell'operatore. La superficie di appoggio deve essere asciutta e comunque non scivolosa.
- **Lontano da persone o animali.** Un movimento errato, la proiezione di schegge e detriti potrebbe mettere in pericolo l'incolumità fisica delle persone o animali presenti.
- **Riparato.** Eventi atmosferici come pioggia, neve, grandine, nebbia, umidità o calore eccessivi possono creare situazioni pericolose, evitare l'uso in concomitanza di questi eventi. Tenere lontano dalla luce diretta del sole per periodi prolungati: il surriscaldamento potrebbe creare temperature troppo elevate sul serbatoio del carburante e possibili incendi.

### IDONEITÀ DELL'OPERATORE.

- **Non assumere droghe, farmaci, alcolici, prima o durante l'utilizzo.** Non sottovalutare anche stati psicofisici temporanei come sonnolenza o intorpidimento dovuti a particolari condizioni climatiche. Curare l'alimentazione e l'idratazione durante l'utilizzo per evitare effetti negativi sui riflessi.
- **La motosega non va utilizzata da persone prive dei necessari requisiti psico-fisici.** Se per qualche motivo (malessere temporaneo, malattia) non si è in grado di maneggiare e control-

lare la motosega, non utilizzarla. Non eccedere la propria personale capacità fisica di sostenere per lunghi periodi il lavoro di taglio con la motosega: si consiglia di lavorare per periodi brevi, intervallati sempre da momenti di riposo per il recupero delle energie. I bambini, le persone non addestrate all'utilizzo o fisicamente inabili non devono in nessun caso utilizzare la motosega e devono sempre stare lontani dal raggio operativo della macchina.

- **UTILIZZARE IDONEE PROTEZIONI.** Indossare sempre occhiali di protezione, casco con visiera, guanti, cuffie antirumore, indumenti resistenti che proteggano il corpo dalla proiezione di schegge o altri materiali. Indossare specifici indumenti antitaglio e calzature antinfortunistiche.
- **SEGUIRE LE NORMATIVE LOCALI.**
  - Non utilizzare in ambienti o in orari vietati dalle normative locali.
  - Evitare l'uso in ambienti in cui sia importante contenere il livello di emissioni sonore in certi orari o a certi livelli massimi. Verificare le condizioni con i soggetti coinvolti.

**Vinco Srl, licenziataria di Hyundai Power Products in Italia, si riserva di modificare le caratteristiche dei prodotti descritti in questo manuale senza preavviso.**

**ATTENZIONE: l'inosservanza per colpa o dolo delle indicazioni di sicurezza, uso e manutenzione contenuti in questo manuale è motivo di decadenza della Garanzia sul prodotto e dei servizi garantiti da Vinco Srl – Hyundai Power Products.**

# CONOSCENZA GENERICA DELLA MOTOSEGA

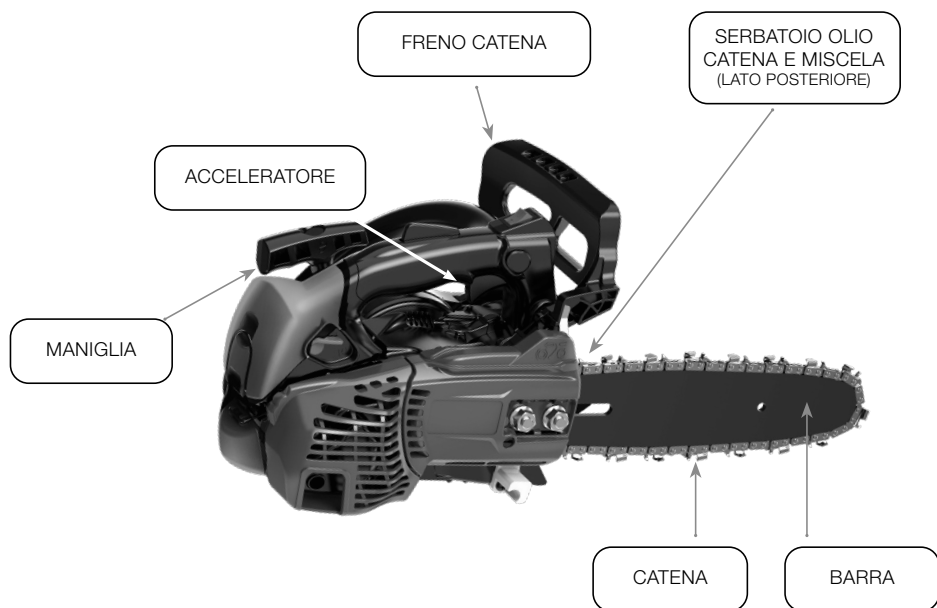

## OPERAZIONI DI PREPARAZIONE AL PRIMO UTILIZZO

### MONTAGGIO DELLA BARRA E DELLA CATENA

- Tirare la leva del freno presente nella figura sottostante verso l'impugnatura: ciò per assicurarsi che il freno catena sia disattivo
- Svitare i 2 bulloni (vedere figura) sul lato della motosega utilizzando la chiave in dotazione



## VIDEO ISTRUZIONI MONTAGGIO CATENA E BARRA



COPERTURA DA RIMUOVERE

BULLONI DA SVITARE PER  
MONTAGGIO CATENA

- Rimuovere la copertura protettiva
- Montare la barra sui perni di fissaggio come indicato nella figura sotto

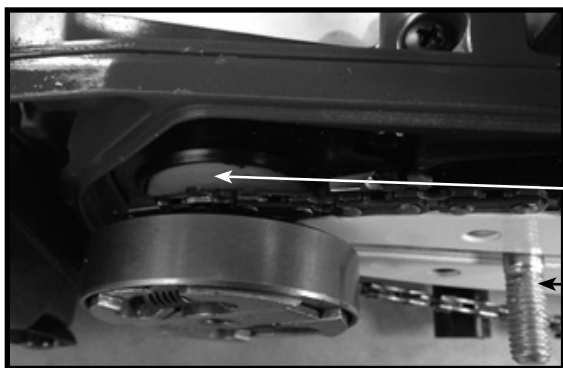

PIGNONE SU CUI INSERIRE  
LA CATENA

PERNO SU CUI INSERIRE  
LA BARRA

- Montare la catena sulla barra. Inserire la catena in modo che la parte inferiore si inserisca agevolmente nella scanalatura della barra e che sia appoggiata sul pignone dell'albero motore in modo che possa scorrere senza impedimenti. **ATTENZIONE AL VERSO DI MONTAGGIO DELLA CATENA**, i denti della catena stessa devono essere orientati come in figura (pagina a lato).



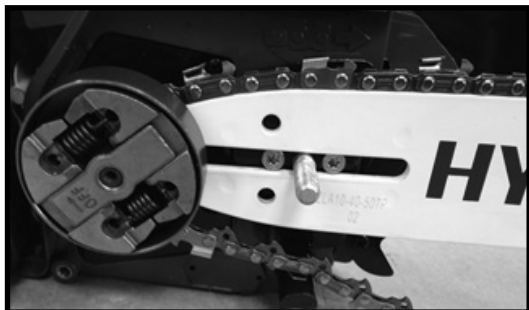

**ATTENZIONE AL VERSO DI  
ROTAZIONE  
DELLA CATENA**

- Controllare che la copertura superiore si infili agevolmente sul perno controllando che il perno del tendicatena sia correttamente posizionato. Se non fosse in posizione, prima di montare la copertura, provare ad avvitare o svitare la vite del tendicatena posta in basso rispetto al bullone di chiusura in metallo (vedere figura sotto).
- Riposizionare la copertura superiore e avvitare i due bulloni. Il bullone più grande in metallo non deve essere serrato totalmente, in questa fase, per poter effettuare una corretta successiva tensione della catena.
- Stringere la catena tramite l'apposita vite tendicatena posta sul lato destro della copertura. Utilizzare l'attrezzo in dotazione. **ATTENZIONE: controllare che la catena sia correttamente inserita nella scanalatura della barra e che sia ben tesa, ma non eccessivamente.** Deve sempre essere possibile poter scostare la catena dalla barra di qualche millimetro. Durante il serraggio della catena, effettuare una trazione verso l'alto, con una mano, della barra. Questo permette un fissaggio migliore.
- Finire di serrare il bullone in metallo che era stato lasciato non totalmente avvitato.

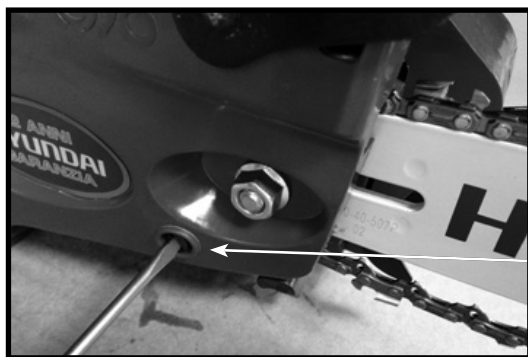

VITE TENDICATENA

- **ATTENZIONE: verificare lo scorrimento della catena, che deve procedere senza sbalzi o irrigidimenti lungo la barra.**

## **RIFORNIMENTO OLIO PER LUBRIFICAZIONE CATENA**

**ATTENZIONE:** utilizzare solo oli specifici per la lubrificazione delle catene da taglio. L'uso di oli non indicati può comportare la formazione di depositi pregiudicando il funzionamento della catena.

Si suggerisce olio per catene da taglio Vinco Oil Pro Cut.

**Non usare oli riciclati o di scarsa qualità: potrebbero compromettere lo scorrimento della catena nella barra e nel legno, provocando blocco o rottura della catena e della barra.**

- Svitare il tappo posto nella parte anteriore in basso del corpo della motosega. **ATTENZIONE:** prestare massima attenzione perché dal tappo superiore si rifornisce di carburante. Sono presenti simboli grafici per evitare confusioni.



- Immettere nel serbatoio l'olio. La capacità massima del serbatoio è di circa ml 20 per tutti modelli.
- Riavvitare il tappo.

## **RIFORMIMENTO MISCELA**

**ATTENZIONE: seguire attentamente le indicazioni di seguito riportate.**

- Utilizzare una miscela di benzina verde e olio specifico per motori 2 tempi.
- Il rapporto olio/benzina deve essere al 2,5% (ml 25 di olio ogni litro di benzina). In condizioni particolarmente gravose di utilizzo si può aumentare la quantità di olio, ma non deve essere mai superiore al 4%. In caso di dubbi, consultare l'Assistenza o un tecnico qualificato.
- Svitare il tappo del serbatoio carburante posto nella parte posteriore in basso del corpo della motosega
- Rifornire di miscela (capacità massima serbatoio: ml 200), ponendo attenzione alle eventuali fuoriuscite di carburante che devono essere immediatamente asciugate per evitare pericolo di incendio.
- Richiudere il tappo del serbatoio.

## MESSA IN MOTO DELLA MOTOSEGA (PRIMA ACCENSIONE – ACCENSIONE A FREDDO)

**ATTENZIONE:** verificare di avere eseguito tutte le operazioni di preparazione precedenti.

Seguire tutte le indicazioni di sicurezza descritte nella sezione “Istruzioni di sicurezza”.

### VIDEO ISTRUZIONI MESSA IN MOTO GENERICA PER MOTOSEGA DA POTATURA



- Posizionare l'interruttore generale rosso di accensione, indicato in figura, nella posizione “1”.
- Premere il pulsante flessibile della pompa carburante alcune volte, fino a che non si veda, in trasparenza, il carburante riempire il vano sottostante il pulsante stesso.
- Tirare verso l'alto la manopola dell'aria sulla posizione di apertura.
- Eseguire l'avviamento tirando energicamente la manopola di avvio. Tenere ben salda la motosega con la mano libera.
- Accelerare: la manopola dell'aria ritornerà automaticamente in posizione di riposo verso il basso.

## MESSA IN MOTO DELLA MOTOSEGA (ACCENSIONE A CALDO)

- Posizionare l'interruttore generale di accensione indicato in figura nella posizione “1”.
- Eseguire l'avviamento tirando energicamente la manopola di avvio sempre mantenendo la motosega ben salda sul piano d'appoggio.

## INDICAZIONI IMPORTANTI DURANTE L'USO

- **ATTENZIONE: verificare sempre tutte le condizioni di sicurezza riguardanti l'operatore e l'ambiente di lavoro descritti in questo manuale alla sezione "Istruzioni di sicurezza"**
- **Impugnare sempre saldamente con le due mani la motosega**, una delle quali deve reggere tramite la maniglia anteriore il peso dell'attrezzo per controllare il taglio, mentre l'altra deve manovrare l'acceleratore posto sull'impugnatura posteriore per direzionare il taglio e accelerare per aumentare la potenza di taglio a seconda delle necessità. La motosega deve essere mantenuta in posizione agevole, il meno stancante possibile, al di sotto del livello delle spalle.
- **Verificare il funzionamento del freno catena: premendo al massimo l'acceleratore, spingere il freno catena in avanti: la catena deve immediatamente fermarsi.** Il freno catena di sicurezza permette il blocco della catena in caso di improvviso arresto del taglio: un contraccolpo potrebbe sbalzare la motosega funzionante contro l'operatore o altre persone presenti e provocare ferite anche gravi. **NON USARE la motosega in caso di malfunzionamento del freno motore e contattare l'Assistenza.**
- Effettuare sessioni di taglio anche intense ma di durata limitata.
- In caso di blocco della motosega all'interno di un tronco durante il taglio, non estrarla con la forza: spegnere il motore utilizzando l'interruttore generale (posizione "0").
- Il freno motore di sicurezza posto sulla parte superiore della maniglia posteriore garantisce, in caso di perdita di presa, il blocco della catena.

## SPEGNIMENTO DELLA MOTOSEGA

- Una volta terminato il lavoro, rilasciare l'acceleratore. Lasciare che il motore giri al minimo per circa 30 secondi.
- Spostare l'interruttore di accensione in posizione "0". La motosega si spegne.

## REGOLAZIONE DEL FLUSSO OLIO LUBRIFICANTE DELLA CATENA

**ATTENZIONE: verificare ad ogni utilizzo il flusso dell'olio di lubrificazione della catena.**

La catena viene lubrificata costantemente grazie alla pompa che spruzza direttamente sulla catena l'olio lubrificante, quando viene usato l'acceleratore. Il rilascio di alcune gocce di olio successivamente allo spegnimento della motosega è del tutto normale.

Se si nota, durante il lavoro, un costante blocco della catena e un surriscaldamento della stessa, ciò potrebbe dipendere da una insufficiente lubrificazione. Al contrario, un flusso eccessivo di olio potrebbe essere inutile.

- A motosega spenta, capovolgerla. Sul fondo si noterà un incavo con una vite di regolazione. Sono riportate sulla scocca plastica le indicazioni di regolazione.
- Seguendo le indicazioni, incrementare il flusso d'olio avvitando in senso antiorario (verso "Max") o in senso orario (verso "Min") per diminuirlo.

- Accendere regolarmente la motosega e provare se il flusso lubrificante dell'olio sia adeguato accelerando brevemente e provando a tagliare sul legno.

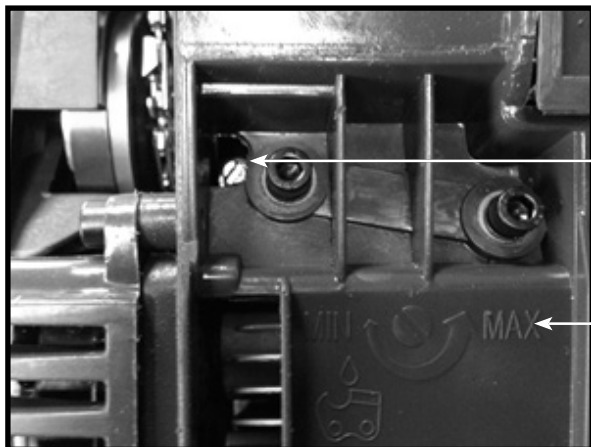

VITE DI REGOLAZIONE  
OLIO CATENA

INDICAZIONI REGOLAZIONE  
OLIO CATENA

## STOCCAGGIO

- Riporre sempre la motosega pulita: liberare la scocca, la barra e la catena dai detriti di taglio. Utilizzare aria compressa per liberare dalla polvere e dalla segatura tutte le parti. Per la pulizia, non utilizzare solventi o liquidi infiammabili come alcool, benzina o petrolio, ma comuni detergenti per la pulizia di plastica e metalli.
- Se il successivo utilizzo avverrà presumibilmente dopo oltre un mese, svuotare il serbatoio della miscela. Il carburante non utilizzato infatti tende a separare nel tempo il lubrificante dalla benzina, aumentando la possibilità di grippaggio del motore al successivo utilizzo. Inoltre, potrebbero crearsi morchie e depositi, causa di problemi nel funzionamento del motore e in particolare del carburatore.
- Riporre in un luogo fresco, asciutto, al riparo dagli agenti atmosferici. Non esporre a temperature eccessive (superiori a 40°C) o troppo basse (possibilmente non inferiori ai 10°C, e mai inferiori a 0°C) per un tempo prolungato.

## MANUTENZIONE

**Attenzione:** è assolutamente indispensabile praticare la manutenzione ordinaria della motosega, per utilizzarla a lungo e in maniera sicura. Lasciare sempre raffreddare la motosega prima di effettuare qualsiasi operazione di manutenzione.

**Indossare sempre indumenti protettivi e guanti durante le operazioni di manutenzione.**

Il servizio di Assistenza con ritiro a domicilio **NON** fornisce prestazioni di manutenzione ordinaria, di seguito elencate, a titolo gratuito.

**Se, in caso d'intervento, l'Assistenza rilevasse eventuali problemi di funzionamento causati da manutenzione errata o carente, eventuali riparazioni saranno eseguite fuori garanzia (vedere para-**

grafo successivo “Condizioni di Garanzia e Assistenza”).

- **RODAGGIO.** Per questa motosega non è necessario un periodo di rodaggio. E' sufficiente effettuare un controllo visivo e serraggi di eventuali bulloni. Controllare il consumo di olio per la catena.
- **CONTROLLO OLIO LUBRIFICAZIONE CATENA. FREQUENZA: PRIMA DI OGNI UTILIZZO.** Effettuare il controllo e il ripristino del livello dell'olio secondo la procedura indicata nel precedente paragrafo “Rifornimento olio lubrificazione catena”.
- **PULIZIA GENERALE. FREQUENZA: DOPO OGNI UTILIZZO.** Smontare la barra di taglio, pulirne la scanalatura interna, rimuovere tutti i detriti, se possibile con aria compressa per eliminarli dagli interstizi.
- **FILTRO ARIA. FREQUENZA: DOPO OGNI UTILIZZO.** Accedere al vano filtro aria ruotando la manopola posteriore. Rimuovere il filtro dell'aria e lavarlo con acqua e sapone oppure con aria compressa.



MANOPOLA SBLOCCO  
VANO FILTRO/CANDELA

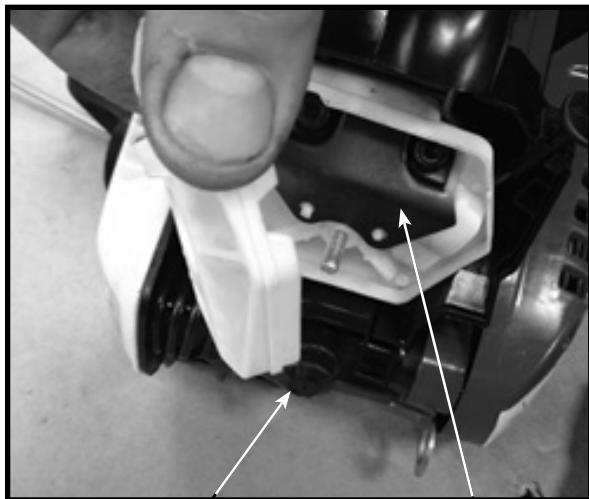

CAPPUCCIO CANDELA

MANOPOLA SBLOCCO  
VANO FILTRO/CANDELA

Richiudere il vano del filtro, riposizionare la copertura posteriore utilizzando e assicurandola con la manopola di sblocco/blocco vano.

• **VERIFICA CANDELA. FREQUENZA: OGNI 10 ORE DI UTILIZZO.** Accedere alla candela dallo stesso vano del filtro aria. Rimuovere il cappuccio di protezione, svitare con l'apposito attrezzo. Verificare la distanza tra gli elettrodi tramite spessimetro (0,6/0,7 mm). Pulire gli elettrodi utilizzando idonei sgrassanti e se necessario tramite abrasione fisica. Se la candela risultasse lesionata o non funzionante dopo la pulitura e la regolazione, sostituire con un'altra di **tipo L7T**. Prima di rimontare la candela, tirare la manopola di avviamento più volte e con la leva dell'aria in posizione aperta. Ciò contribuirà a pulire e ventilare la camera di scoppio.

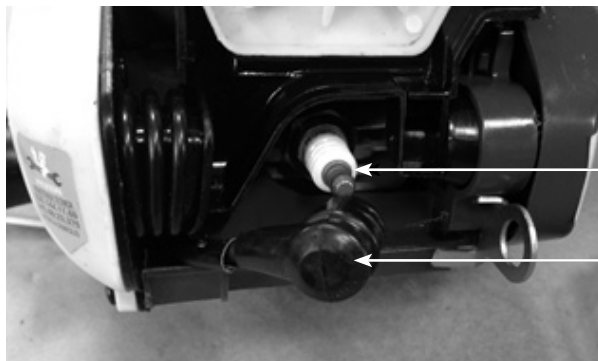

CANDELA L7T

CAPPUCCIO PROTEZIONE  
CANDELA

Rimontare quindi la candela e riagganciare il cappuccio di protezione.

• **INGRASSO PIGNONE. FREQUENZA: OGNI 10 ORE DI UTILIZZO.** Accedere al pignone smontando la motosega come indicato nella procedura “Montaggio della barra e della catena”. Dopo aver rimosso qualsiasi detrito e sporcizia, ingrassare con prodotti idonei.

• **AFFILATURA CATENA. FREQUENZA: QUANDO SI PRESENTANO I SEGUENTI PROBLEMI.**

- Serve una eccessiva pressione per effettuare il taglio
- Il taglio produce una segatura fine anziché piccoli trucioli
- Durante il taglio, nonostante la lubrificazione della catena, si genera fumo
- Il taglio è irregolare, la motosega vibra e la catena procede a saltelli
- Se questi problemi persistono, sostituire con una catena nuova differente a seconda del modello.

• **FILTRO CARBURANTE. FREQUENZA: OGNI 20 ORE DI UTILIZZO.** Accedere al filtro aprendo il tappo del serbatoio del carburante. Estrarre con l'aiuto di un attrezzo il filtro. Rimuovere le impurità o sostituirlo.

• **SOSTITUZIONE CARBURANTE. FREQUENZA: OGNI QUALVOLTA LA MOTOSEGA NON VENGA UTILIZZATA PER OLTRE 1 MESE.** Per preservare l'integrità delle componenti si consiglia di svuotare il serbatoio del carburante, per evitare che la miscela separi le proprie componenti molecolari, perdendo le proprietà lubrificanti, e che si formino impurità e morchie sugli organi meccanici e all'interno delle tubazioni.

## PROBLEMI DI FUNZIONAMENTO E SOLUZIONI

• **LA MOTOSEGA NON PARTE.** Verificare:

- Pulsante di accensione su “1”.
- La presenza del carburante nel serbatoio. Se il pulsante della pompa carburante è vuoto internamente, il carburante non ha raggiunto il carburatore. Effettuare alcuni pompaggi premendo finché il pulsante non risulti visibilmente pieno di miscela.

- **La sequenza delle operazioni di avvio.** Consultare i paragrafi precedenti relativi alla messa in moto – distinguendo se “a caldo” o “a freddo”.
- **La pulizia della candela.** Eseguire le operazioni di manutenzione descritte nel paragrafo “Manutenzione”.
- **L’efficienza della bobina di accensione.** Verificare se, tirando la manopola di avvio, si genera una scintilla dal cappuccio di collegamento della candela. Qualora queste operazioni non abbiano avuto efficacia, non insistere ulteriormente e contattare l’Assistenza o un Tecnico Specializzato.
- **LA MOTOSEGA NON TAGLIA EFFICACEMENTE.** Probabile necessità di affilare o sostituire la catena.
- **IL MOTORE FUNZIONA CORRETTAMENTE, MA LA MOTOSEGA EMETTE UN RUMORE METALLICO E/O DI SFREGAMENTO QUANDO SI ACCELERA.** Verificare il posizionamento e la tensione della catena di taglio. Se il rumore persiste, contattare l’Assistenza Tecnica.
- **FUMO ECCESSIVO DALLO SCARICO DEL MOTORE.** Verificare che la composizione della miscela non abbia una quantità eccessiva di olio. Concentrazioni di olio superiori al 2,5% possono generare un aumento dei fumi; oltre il 4% si possono verificare seri problemi di funzionamento, quali inefficienza della candela, emissione di fumi di scarico oleosi e infiammabili, degenerazione della capacità del carburatore. Verificare anche la pulizia del filtro carburante.
- **FUMO ECCESSIVO DURANTE IL TAGLIO PROVENIENTE DALLA CATENA.** Verificare che la pompa dell’olio spruzzi l’olio sulla catena in quantità sufficiente. Nel caso, effettuare la regolazione come indicato nel paragrafo “Rifornimento olio per lubrificazione catena”.
- **FUMO DAL CORPO MOTORE.** E’ possibile che alcuni residui di taglio si siano depositati sul corpo del motore. Spegnerne immediatamente la motosega, lasciarla raffreddare, accedere al vano motore e soffiare via con aria compressa le impurità presenti. Se durante l’utilizzo successivo il fumo persiste, potrebbe trattarsi della frizione. Consultare il Servizio di Assistenza Tecnica.
- **IL MOTORE DELLA MOTOSEGA GIRA IRREGOLARMENTE AL MINIMO.** Controllare la pulizia della candela e del filtro carburante. Contattare l’Assistenza Tecnica.
- **DOPO L’UTILIZZO SI FORMA UNA PICCOLA MACCHIA D’OLIO SOTTO LA MOTOSEGA.** Si tratta probabilmente di alcune gocce di olio lubrificante per la catena residue. E’ del tutto normale. Se l’estensione della macchia d’olio fosse notevole, controllare la regolazione della pompa olio come indicato nel paragrafo precedente “Regolazione del flusso olio lubrificante della catena”.

## SMALTIMENTO

Effettuare lo smaltimento del prodotto a fine vita secondo le normative.

Separare gli imballaggi riciclabili in carta, cartone e plastica e smaltirli come indicato localmente.



# COD. 35520

## MOD. TCS2510

<b>CILINDRATA</b>	<b>25 cc</b>
<b>POTENZA</b>	<b>1,5 HP/1,0 Kw</b>
<b>LUNGHEZZA BARRA</b>	<b>25 cm</b>
<b>CAPACITÀ DI TAGLIO</b>	<b>200 mm</b>
<b>PASSO CATENA</b>	<b>3/8"</b>
<b>CAPACITÀ CARBURANTE</b>	<b>200 ml</b>
<b>CAPACITÀ OLIO</b>	<b>120 ml</b>
<b>DIMENSIONI PRODOTTO</b>	<b>23x26x25 cm</b>
<b>PESO NETTO/LORDO</b>	<b>2,5/3,5 Kg</b>



### CONDIZIONI DI GARANZIA E ASSISTENZA

Fatte salve le "condizioni di decadenza della garanzia legale" riportate in questo libretto, il Rivenditore Hyundai Power Products applicherà le condizioni previste dalla normativa in vigore.

Vinco Srl, in qualità di Licenziatario per l'Italia dei prodotti Hyundai Power Products, applica una garanzia commerciale a supporto dell'attività del Rivenditore autorizzato.

Il Rivenditore autorizzato e il Consumatore finale possono rivolgersi quindi direttamente al Centro di Assistenza Tecnica

Vinco Srl per:

- **Informazioni tecniche su uso e manutenzione.**
- **Interventi relativi all'assistenza tecnica del prodotto**, quali riparazione o sostituzione del prodotto, qualora il cliente sia in possesso di documento di acquisto precedente i 24 mesi dalla data della presentazione della problematica (12 mesi se bene strumentale). Il servizio è disponibile a pagamento anche per i prodotti fuori garanzia e comprende ritiro e riconsegna presso l'indirizzo del richiedente. L'Assistenza Tecnica Vinco Srl può demandare a terze parti lo svolgimento di operazioni di riparazione autorizzate.
- **Servizio di ritiro a domicilio.** Per alcune categorie di prodotto è prevista, quando indicato sulla confezione del prodotto, il servizio di ritiro a domicilio del Cliente, riparazione e riconsegna a titolo gratuito, per tutta la durata della garanzia legale. Il ritiro a domicilio viene accordato a insindacabile giudizio del servizio di Assistenza Tecnica Vinco Srl (fermi restando tutti gli altri obblighi di garanzia legale).

- **Invio a titolo gratuito di parti o ricambi** per prodotti in Garanzia legale. Tale invio viene deciso a insindacabile giudizio del servizio di Assistenza Tecnica Vinco Srl qualora riguardi la sostituzione di parti secondarie o con funzione estetica. Tutti i ricambi che riguardano la manutenzione ordinaria (elenco indicativo non esaustivo: candele, filtri, oli) sono sempre a pagamento.

## **ASSISTENZA TECNICA VINCO SRL – HYUNDAI POWER PRODUCTS**

E' possibile contattare l'Assistenza nei seguenti modi.

- **Compilando l'apposito Form sul sito WWW.VINCOASTI.COM** alla sezione "Assistenza". Attenzione, **per il ritiro a domicilio è necessario munirsi di codice di autorizzazione fornito contattando il Centro di Assistenza stesso**, raggiungibile nei modi che seguono.

- **Call Center Tecnico.** Attivo tutti i giorni lavorativi negli orari 10-12/15-17:

**0141 176.63.15**

- **E-mail.** Per l'attivazione dei servizi di Assistenza o per conoscere lo stato di una riparazione:

**assistenza@vincoasti.it**

per la richiesta di ricambi:

**ricambi@vincoasti.it**

- **Fax.** Nel caso non fosse disponibile l'utilizzo di una casella e-mail è possibile inviare la propria richiesta di assistenza al numero:

**0141 35.12.85**

Assistenza Tecnica Vinco Hyundai Power Products, Viale Giordana 7, 10024 Moncalieri

**Attenzione: il servizio di Assistenza Tecnica NON è aperto al pubblico. Contattare il numero telefonico 0141 176.63.15 per qualsiasi necessità.**

**VIDEO ISTRUZIONI  
ASSISTENZA VINCO HYUNDAI  
E COME RICHIEDERLA**



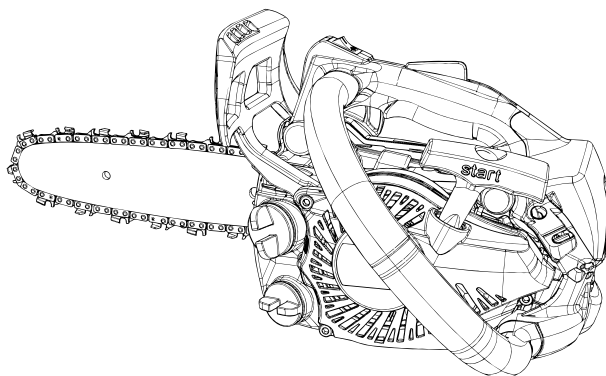

# **INSTRUCTION MANUAL**

## **CHAINSAW**

### **TCS2510**

#### **⚠ WARNING**



This chain saw is designed especially for tree service by a trained operator.

Read the instructions carefully and follow the rules for safe operation.

Failure to do so could result in serious injury.

# Introduction

---

This chain saw is designed for cutting wood or wood products.  
Do not cut solid metal, sheet metal, plastic or any non-wood materials.

National or local regulation can restrict the use of this chain saw.

It is important for you to understand all safety precautions correctly before using your chain saw.  
Misuse of the chain saw can cause serious bodily injury.  
Never let children operate the saw.

This manual shows rules of safe operation, proper use, servicing, and maintenance of your chain saw.  
Follow these instructions in order to maintain a good operating condition and a long service life.  
For future reference, you should keep this operator's manual.  
If this operator's manual has become illegible through impairment or is lost, please purchase a new one from your dealer.

When renting or lending this machine to a person who will operate it, always include this operator's manual, which provides explanation and instructions.  
When transferring a product, please deliver it attaching the operator's manual.

Specifications, descriptions and illustrative material in this literature are as accurate as known at the time of publication, but are subject to change without notice.  
Illustrations may include optional equipment and accessories, and may not include all standard equipment.  
The unit is delivered with guide bar and saw chain separated.  
Install guide bar and chain.  
If there is any clause in this manual that is hard to be understood, please contact your dealer.

## Decals and symbols

### DANGER

This symbol accompanied by the word "DANGER" calls attentions to an act or a condition which will lead to serious personal injury or death of operators and bystanders.

### WARNING

This symbol accompanied by the word "WARNING" calls attentions to an act or a condition which can lead to serious personal injury or death of operators and bystanders.

### CAUTION

"CAUTION" indicates a potentially hazardous situation which, if not avoided, may result in minor or moderate injury.

















Circle and slash symbol means whatever is shown is prohibited.

### NOTE

This enclosed message provide tips for use, care and maintenance of the unit.

### IMPORTANT

Framed text featuring the word "IMPORTANT" contains important information about the use, checking, maintenance and storage of the product described in this manual.

Symbol form / shape	Symbol description / application	Symbol form / shape	Symbol description / application
	Carefully read the operator's manual		Chain brake operation
	This chain-saw is for trained tree service operators only.		Oil and petrol mixture
	One handed operation of the saw can be dangerous.		Chain oil fill
	Appropriate ear, eye, and head protection must be worn.		Chain oiler adjustment
	Use appropriate protection for foot-leg and hand-arm.		Purge bulb (Primer)
	Warning! Kickback may occur!		Carburettor adjustment - Idle speed
	Beware of high-temperature areas		Guaranteed sound power level
	Emergency stop		

Locate this safety decal on your unit.  
The complete unit illustration found in the "Description" section will help you locate them.

Make sure the decal is legible and that you understand and follow the instructions on it.  
If a decal cannot be read, a new one can be ordered from your dealer.

# Rules for safe operation

## 1. Tree service chain saw



### NOTE

When replacing guide bar or saw chain, ask your dealer.

- The saw is specially designed for tree service, i.e. for off-ground working in trees, and when being used as such should only be used by trained operators. One handed operation of the saw can be dangerous.
- Be alert for the phenomena "skating" and "bouncing", greater risk from kickback. Be cautious not to lose balance of your body due to "drop" at the end of a cut.
- If working off the ground the operator must be trained in safe climbing techniques and use of all recommended safety equipment such as harness, loops, strops, ropes and karabiners for himself and for the saw.
- When hoisting a chain saw using a rope tied to a lifting hook for operation on a tree, ensure that the lifting hook is not strained by excessive force.

### General requirements

Operators of tree service chain-saws working at height from a rope and harness should never work alone.

A ground worker trained in appropriate emergency procedures should assist them.

Operators of tree service chain-saws for this work should be trained in general safe climbing and work positioning techniques and be properly equipped with harnesses, ropes, strops, carabiners and other equipment for maintaining secure and safe working positions for both themselves and the saw.

### Preparing to use the saw in the tree

The chain-saw should be checked, fuelled, started and warmed up by the ground worker and then switched off before it is sent up to the operator in the tree.

The chain-saw should be fitted with a suitable strop for attachment to the operator's harness:

#### Example of attachment of chain-saw to operator's harness

- secure the strop around the attachment point on the rear of the saw;
- provide suitable karabiners to allow indirect (i.e. via the strop) and direct attachment (i.e. at the attachment point on the saw) of the saw to the operator's harness;
- ensure the saw is securely attached when it is being sent up to the operator;
- ensure the saw is secured to the harness before it is disconnected from the means of ascent.

The ability to directly attach the saw to the harness reduces the risk of damage to equipment when moving around the tree.

Always switch the saw off when it is directly attached to the harness.

#### Example of attachment of chain-saw to centre rear mid-point on harness

The saw should only be attached to the recommended attachment points on the harness.

These may be at mid-point (front or rear) or at the sides.

Where possible, attach the saw to centre rear mid-point to keep it clear of climbing lines and to support its weight centrally down the operator's spine.

When moving the saw from any one attachment point to another, operators should ensure it is secured in the new position before releasing it from the previous attachment point.

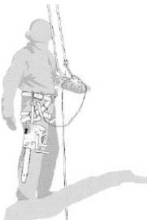

## Using the chain-saw in the tree

An analysis of accidents with these saws during tree service operations shows the primary cause as being inappropriate one-handed use of the saw.

In the vast majority of accidents, operators fail to adopt a secure work position that allows them to hold both handles of the saw.

This results in an increased risk of injury due to

- not having a firm grip on the saw if it kicks back,
- a lack of control of the saw such that it is more likely to come into contact with climbing lines and the operator's body (particularly the left hand and arm), and
- loss of control owing to an insecure work position and resulting in contact with the saw (unexpected movement during operation of the saw).

### 1. Securing the work position for two-handed use

In order to allow the saw to be held with both hands, as a general rule operators should aim for a secure work position in which they operate the saw at

- hip level, when cutting horizontal sections, and
- solar plexus level, when cutting vertical sections.

### Example of redirection of the main line via supplementary anchor point

Where the operator is working close into vertical stems with low lateral forces on the work position, then a good footing could be all that is needed to maintain a secure work position. However, as operators move away from the stem, they will need to take steps to remove or counteract the increasing lateral forces by, for example, a redirect of the main line via a supplementary anchor point or using an adjustable strop direct from the harness to a supplementary anchor point.



### Example of temporary foot stirrup created from endless sling

Gaining a good footing at the working position can be assisted by the use of a temporary foot stirrup created from an endless sling.

### 2. Starting the saw in the tree

When starting the saw in the tree, the operator should

- apply the chain brake before starting,
- hold the saw on either the left or right of the body when starting,
  1. on the left side, hold the saw with the left hand on the front handle and thrust the saw away from the body while holding the pull starter cord in the right hand, or
  2. on the right side, hold the saw with the right hand on either handle and thrust the saw away from the body while holding the pull starter cord in the left hand.

The chain brake should always be engaged before lowering a running saw onto its strop. Operators should always check that the saw has sufficient fuel before undertaking critical cuts.



### 3. One-hand use of the chain-saw

Operators should not use tree service chain-saws one-handed when work position is unstable or in preference to a handsaw when cutting small diameter wood at the branch tips.

Tree service chain-saws should only be used one-handed where

- operators cannot gain a work position enabling two-handed use, and
- they need to support their working position with one hand, and
- the saw is being used at full stretch, at right angles to and out of line with the operator's body.



### Example of one-handed chain-saw use

Operators should never

- cut with the kickback zone at the tip of the chain-saw guide bar,
- "hold and cut" sections, or
- attempt to catch falling sections.

### 4. Freeing a trapped saw

If the saw become trapped during cutting, operators should

- switch off the saw and attach it securely to the tree inboard (i.e. towards the trunk side) of the cut or to a separate tool line,
- pull the saw from the kerf whilst lifting the branch as necessary,
- if necessary, use a handsaw or second chain saw to release the trapped saw by cutting a minimum of 30 cm away from the trapped saw.

Whether a handsaw or a chain-saw is used to free a trapped saw, the release cuts should always be outboard (toward the tips of the branch), in order to prevent the saw being taken with the section and further complicating the situation.



## 2. General precautions

### Operator's manual



- Read the operator's manual for your chain saw carefully. Be thoroughly familiar with the chain saw's controls and how to use the chain saw properly. Failure to follow instructions could lead to personal injury.
- If you have any questions or problems, please contact your dealer.

### Physical condition



- Do not operate a chain saw when you are fatigued or under the influence of alcohol or drugs.
- You should be in good physical and mental health in order to handle your chain saw safely. Errors in judgement or execution can be serious or fatal. If you have any physical condition which strenuous work could worsen, check with your physician before using a chain saw. Do not operate when ill or fatigued, or under the influence of any substance or medication which could affect your vision, dexterity or judgement.

### Personal equipment

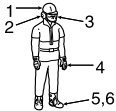

**CAUTION**  
Stuffing ears with cotton is not recommended.

- Always wear approved goggles to protect your eyes. Wood chips, dust, snapping branches and other debris can be thrown by the cutting chain into the operator's facial area. Goggles may also offer limited protection in the event of the cutting chain hitting the operator in the eye area. If conditions warrant that a ventilated face shield be worn, goggles must be worn underneath it.
- Advises wearing hearing protection at all times. If not followed, hearing loss can occur. You should reduce the risk of hearing damage by wearing either "headset" type protectors or ear plugs which are approved by an authorized organization.
- All persons who make part of their living using chain saws should be tested periodically for hearing deterioration.
- Always wear a helmet when working with a chain saw. A safety hard helmet is highly recommended when felling or working under trees, or when objects can fall on you.
- Wear heavy duty, non-slip gloves for improved grip, and also for protection against cold and vibration.
- Safety tip shoes or boots with non-slip sole should be worn.
- Never wear loose clothing, unbuttoned jackets, flared sleeves and cuffs, scarves, tie-strings, neckties, cords, chains, jewellery, etc. which could snag the saw chain or underbrush.
- Clothing should be of sturdy, protective material. It should be snug-fitting to resist snagging, but roomy enough for freedom of movement.
- Trouser legs should not be flared or cuffed, and should be either tucked into the boot tops or trimmed short.
- Safety vests, leg chaps and logger's pants of ballistic material are available. It is the operator's responsibility to wear such additional protection if conditions warrant it.
- Never operate a chain saw when you are alone. Arrange to have someone remain within calling distance in case you need help.

## Fuel



### DANGER

- ♦ Petrol and fuel are extremely flammable. If spilled or ignited by ignition source, it can cause fire and serious injury or property damage. Extreme caution is required when handling petrol or fuel.
- ♦ After refuelling, tighten fuel cap firmly and check for leakage. In case of fuel leakage, repair before starting operation since there is a danger of fire.

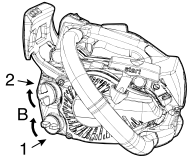
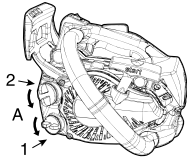

1. Oil tank cap
  2. Fuel tank cap
- A: Loosening direction  
B: Tightening direction

- Use an appropriate type of fuel container.
- Bring an extinguisher or shovel in case of fire. Despite the precautions which can be taken, operating a chain saw, or just working in the forest, presents dangers.
- Do not smoke or bring flame or sparks near to fuel supplies.
- The fuel tank may be under pressure. Always loosen the fuel cap and wait for pressure to be equalized before removing the cap.
- Turn anti-clockwise to open the oil cap and fuel cap

- Fill the fuel tank outdoors over bare ground and install the fuel cap securely. Do not pour fuel indoors.
- Wipe any spilled fuel off the unit.
- Never refuel while the engine is still hot, or fuel a running engine.
- Do not store the unit with fuel in its tank, because a fuel leak could start a fire.
- Always fill up the chain oil first, then fill up the fuel mixture.

## Starting engine

### DANGER

**Do not drop start the chain saw, drop start puts chain saw in an insecure position and can result in injury.**

**Start the chain saw in a correct manner.**

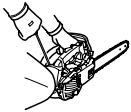
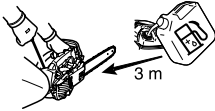

- Move the chain saw at least 3 m from the fuelling point before starting the engine.
- Do not allow other persons to be near the chain saw when you are starting or cutting with the chain saw.  
Keep bystanders and animals out of the work area.  
Do not let anyone hold wood for you to cut.
- Do not start cutting until you have a clear work area, secure footing and a planned retreat path from the falling tree.
- Before you start the engine, make sure that the saw chain is not contacting anything.
- Keep the handles dry, clean, and free of oil or fuel mixture.
- Operate the chain saw only in well-ventilated areas.  
Exhaust gas, oil mist (from chain saw lubrication) or saw dust is harmful to health.
- When starting the chain saw place the unit on a flat ground and hold the front handle with left hand and hold firmly the rear end of rear handle with right knee and pull starter handle with right hand.

## Transportation

1. Guide bar cover
- When transporting your chain saw, use the appropriate guide bar cover.
  - Carry the chain saw with the engine stopped, the guide bar and saw chain to the rear, and the silencer away from your body.

### Transport and storage

- Always keep the engine shut off and make it certain that cutting device is securely covered. When transporting the machine, properly secure it to prevent flipping over, fuel spillage and damage to the unit.

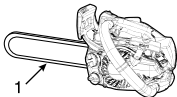

### 3. Kickback safety precautions

#### DANGER

**Kickback safety precaution for chain saw users: kickback may occur when the nose or tip of the guide bar touches an object or when the wood closes in and pinches the saw chain in the cut.**

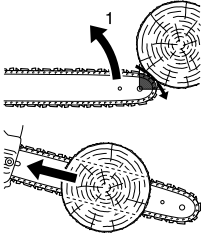

#### 1. High kickback

- In some cases, tip contact may cause a lightning-fast reverse reaction, kicking the guide bar up and back toward the operator (this is called a rotational kickback). Pinching the saw chain along the top of the guide bar may push the guide bar rapidly back toward the operator (this is called a linear kickback).
- Either of these reactions may cause you to lose control of the saw and come in contact with the moving chain, which could result in serious personal injury. As a chain saw user, you should take several steps to keep your cutting jobs free from accident or injury.
- With a basic understanding of kickback, you can reduce or eliminate the element of surprise. Sudden surprise contributes to accidents. Understand that rotational kickback is preventable by keeping an unshielded bar nose from touching an object or the ground.
- Do not operate a chain saw with one hand! Serious injury to the operator, helpers or bystanders may result from one-handed operation. For proper control, always use two hands when operating a chain saw, one of which operates the trigger. Otherwise, this can result in the chain saw "skating" or skidding, which can result in personal injury due to loss of control.
- Keep a good firm grip on the saw which both hands, with the right hand on the rear handle and the left hand on the front handle, when the engine is running. Use a firm grip with thumbs and fingers encircling the chain saw handles. A firm grip will help you reduce kickback and maintain control of the saw. Two hands must be used to control the saw at all times.
- Do not overreach or cut above chest height.
- Make sure that the area in which you are cutting is free from obstructions. Do not let the bar nose contact a log, branch, or any other obstruction which could be hit while you are operating the saw.
- Cutting at high engine speeds may reduce the likelihood of kickback. But cutting at part-throttle or low engine speeds may be preferable to control the chain saw in tight situations and may also reduce the likelihood of kickback.
- Follow manufacturer's sharpening and maintenance instructions for the saw chain.
- Use only replacement guide bars and chains specified by the manufacturer, or the acceptable equivalents of these guide bars and chains.

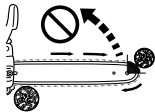

## 4. Other safety precautions

### Vibration and cold



It is believed that a condition called Raynaud's Phenomenon, which affects the fingers of certain individuals, may be brought about by exposure to cold and vibration.

Accordingly, your chain saw has an anti-vibration device designed to reduce the intensity of vibration received through the handles.

Exposure to cold and vibration may cause tingling and burning followed by loss of colour and numbness in the fingers. (White finger syndrome)

We strongly recommend you take the following precautions because the minimum exposure which might trigger the ailment is unknown.

- Keep your body warm, especially the head and neck, feet and ankles, and hands and wrists.
- Maintain good blood circulation by performing vigorous arm exercises during frequent work breaks and also by not smoking.
- Limit the number of hours of chain saw operation.  
Try to fill a part of each work day with jobs other than chain sawing.
- If you experience discomfort, redness and swelling of the fingers, followed by whitening and loss of feeling, consult your physician before further exposing yourself to cold and vibration.

### Repetitive stress injuries

It is believed that over-using the muscles and tendons of the fingers, hands, arms and shoulders may cause soreness, swelling, numbness, weakness and extreme pain to the areas just mentioned.

To reduce the risk of repetitive stress injury, do the following:

- Avoid using your wrist in a bent, extended or twisted position.  
Instead, try to maintain a straight wrist position.  
Also, when grasping, use your whole hand, not just the thumb and index finger.
- Take periodic breaks to minimize repetition and rest your hands.
- Reduce the speed and force in which you do the repetitive movement.
- Do exercises to strengthen the hand and arm muscles.
- See a doctor if you feel tingling, numbness or pain in the fingers, hands, wrists or arms.

## Machine conditions

### **WARNING**

**Do not modify a chain saw in any way. Only accessories and components provided or explicitly licensed by the manufacturer for a specific model of chainsaw are authorized for use. Although some unauthorized accessories can be used for this device, the use of these accessories is actually extremely dangerous.**

- Do not operate a chain saw that is damaged, improperly adjusted, or not completely and securely assembled.  
Do not operate the chain saw with a loose or defective silencer.  
Be sure that the saw chain stops moving when the throttle control trigger is released.
- If your saw is subjected to high loads due to a fall or impact, always perform inspection and operation check in order to confirm if there is anything wrong before continuing work.

## Cutting

### **CAUTION**

**Do not touch hot surfaces of cylinder cover and silencer after you used the chain saw.**

- Do not operate a chain saw in a tree unless you have been specifically trained to do so.
- Keep all parts of your body away from the saw chain when the engine is running.
- Use extreme caution when cutting small-size brush and saplings because slender material may catch the saw chain and be whipped toward you or pull you off balance.
- Stay on the uphill side when bucking or limbing logs which might roll when cut.
- When cutting a limb that is under tension, be alert for spring-back so that you will not be struck by the limb or chain saw when the tension in the wood fibres is released.
- Cutting while on a ladder is extremely dangerous because the ladder can slip and your control of the chain saw is limited.  
Working aloft should be left to professionals.
- Keep both feet on the ground.  
Do not work from off-the-ground positions.
- Stop the engine before setting the chain saw down.

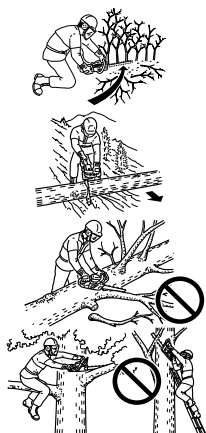

## Wood practices

- Operating a chain saw safely requires a chain saw in proper working order, sound judgement, and knowledge of the methods which should be applied in each cutting situation.
- Do not let any person use your saw unless he has read this operator's manual and fully understands its instructions.
- Use your saw only to cut wood or wood products.  
Do not cut solid metal, sheet metal, plastics or any non-wood materials.

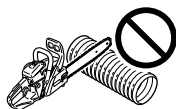

## Services

- All chain saw service operations, other than items listed in the operator's manual maintenance instructions, should be performed by competent service personnel.  
(For example, if an improper tool is used to hold the flywheel in order to remove the clutch, structural damage to the flywheel could occur and subsequently could cause the flywheel to burst.)

## Description

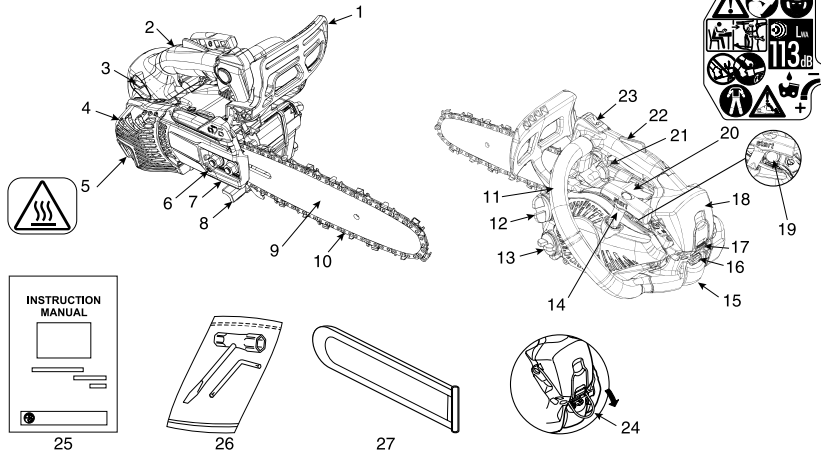

1. **Front hand guard** - Guard between the front handle and the saw chain for protecting the hand from injuries and aiding in control of the chain saw if the hand slips off the handle.  
This guard is used to activate the chain brake which is to stop the saw chain rotation.
2. **Rear handle (for the right hand)** - Support handle located on the top of the engine housing.
3. **Choke control knob** - Device for enriching the fuel / air mixture in the carburettor to aid cold starting.
4. **Silencer cover** - Cover the silencer not to make operator touch to hot surface of silencer.
5. **Safety decal**
6. **Chain tension adjuster** - Device to adjust chain tension.
7. **Clutch cover** - Protective cover to the guide bar, saw chain, clutch and sprocket when the chain saw is in use.
8. **Chain catcher** - A projection designed to reduce the risk of the operator's right hand from being hit by a chain which has broken or derailed from the guide bar during cutting.
9. **Guide bar** - The part that supports and guides the saw chain.
10. **Chain** - Chain, serving as a cutting tool.
11. **Front handle (for the left hand)** - Support handle located at the left side of the engine housing.
12. **Fuel tank cap** - For closing the fuel tank.
13. **Oil tank cap** - For closing the oil tank.
14. **Starter handle** - The grip of the starter, for starting the engine.
15. **Spark plug cover** - Covers spark plug.
16. **Spark plug cover latch** - Device for installing the spark plug cover.
17. **Cleaner cover latch** - Device for installing the air cleaner cover.
18. **Air cleaner cover** - Covers air filter.
19. **Purge bulb (primer pump)** - When starting engine, push primer pump 3 or 4 times.
20. **Safety decal**
21. **Throttle trigger** - Device activated by the operator's finger, for controlling the engine speed.
22. **Throttle trigger lockout** - A safety lever which must be depressed before the throttle trigger can be activated in order to prevent the accidental operation of the throttle trigger.
23. **Ignition switch** - Device for connecting and disconnecting the ignition system and thus allowing the engine to be started or stopped.
24. **Lifting hook** - If working off the ground the operator must be trained in safe climbing techniques and use of all recommended safety equipment.
25. **Operator's manual** - Included with unit.  
Read before operation and keep for future reference to learn proper, safe operating techniques.
26. **Tools** - 13 x 16 mm T-wrench (combination screwdriver / spark plug socket) and L-wrench.
27. **Guide bar cover** - Device for covering the guide bar and saw chain during transport and other times when the chain saw is not in use.

## Assembly

### Mounting guide bar and chain

#### **WARNING**

For your own safety, always stop the engine before performing any of the following operations.

#### **CAUTION**

1. All adjustments should be made cold.
2. Always wear gloves when working on chain.
3. Do not operate with a loose chain.

#### **NOTE**

Move the chain brake lever (Front hand guard, Brake connector) fully rearward to remove or install the clutch cover to the chain saw.

1. Release chain brake
2. A nut
3. Clutch cover
4. Spiked bumper; **option**



Install guide bar and chain as follows.

- Loosen a nut and remove clutch cover.
- Mount the bar and slide toward clutch to make saw chain installation easier.

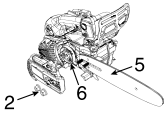

5. Guide bar
6. Clutch

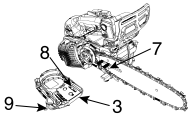

7. Bar hole
8. Tension adjuster pin
9. Brake connector

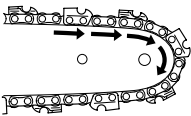

- Install saw chain as shown.  
(Ensure cutters are pointing in the right direction)

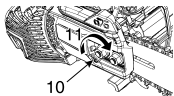

10. Tension adjuster
  11. Direction to tension the chain
- Release the chain brake, and install the clutch cover over the guide bar stud. Tighten a nut finger tight. Ensure that chain tension adjuster fits into bar hole.

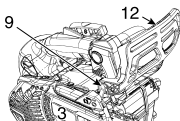

12. Front hand guard (Brake lever)
- Align the brake connector of the clutch cover to the groove on the side of the front hand guard.



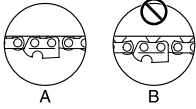

- Hold the bar nose up and turn the adjuster clockwise until the chain fits snugly against the underside of the bar.

A: Proper tension  
B: Improper tension

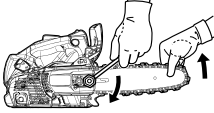

- Tighten the nut with the bar nose held up.
- Pull the chain around the bar by hand.  
Loosen the adjustment if you feel tight spots.

## Checking lifting hook

### IMPORTANT

- If your chain saw falls from height or receives a strong impact to the lifting hook (harness ring), please check its integrity by opening the air cleaner cover (see page 31 "Air filter") to assess that the ring and its associated parts are not damaged or broken.
- In case of being damaged or broken, do not continue using the unit with the lifting hook (harness ring).
- If you have any doubt with regards to their condition, have the unit checked out by your nearest authorized dealer.

1. Air cleaner cover
2. Lifting hook (harness ring)

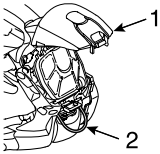

## Operation

### Fuel and lubricant

#### CAUTION

Whenever opening up the fuel tank, always loosen the cap very slowly and wait for the tank pressure to be equalized before removing the cap.



- Fuel is a mixture of regular grade petrol and an air-cooled 2-stroke engine oil of reputable brand name.  
Minimum 89 Octane unleaded petrol is recommended.  
Do not use fuel containing methyl alcohol or more than 10 % of ethyl alcohol.
- Recommended mixture ratio; 50 : 1 (2 %) for ISO-L-EGD Standard (ISO/CD13738), JASO FC, FD grade and 50 : 1 oil.
  - Do not mix directly in engine fuel tank.
  - Avoid spilling petrol or oil.  
Spilled fuel should always be wiped up.
  - Handle petrol with care, it is highly inflammable.
  - Always store fuel in approved container.

### Chain lubricant



- Proper lubrication of the chain while in operation minimizes friction between the chain, the guide bar and sprocket and also clutch components such as needle bearing and clutch assembly.  
Use genuine chain oil or recommended chain oil specially formulated for bars and chains for proper lubrication.  
These oils contain tackifiers, anti-aging and anti-oxidizing agents.  
Consult your dealer for the proper chain oil.
- Never use waste or reclaimed oil to avoid various malfunctions on oil system, clutch system, chain and guide bar.  
Lubrication problems caused by the use of improper oil will void the warranty.
- Especially, vegetable based chain oil quickly turns to resin and adheres to oil pump, chain, guide bar, clutch needle bearing and clutch assembly.  
It causes malfunctions and shorten product life.  
Flush chain oil system with mineral or chemical based chain oil after use, if it is required to use vegetable oil due to local / municipal rule or any other reason.
- For a short time emergency operation, fresh SAE 10W-30 motor oil can be used.

### Cap indication

Fuel and oil tanks are indicated by the following illustrations.

Fuel tank cap  
(Red)

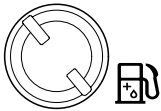

Chain oil tank cap  
(Black)

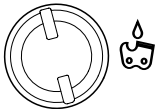

## Starting the cold engine

### **WARNING**

- ◆ After choke control knob is turned and then knob is returned to original position, throttle remains a little open (latch condition).
- ◆ If engine is started in this latch condition, chain starts to turn.  
Do not start engine before chain brake is activated.

### **CAUTION**

1. After starting the engine, immediately squeeze and release throttle trigger for disengaging throttle latch and returning engine to idle, and pull front hand guard towards the operator immediately. (Chain brake RELEASED position)
2. Do not increase engine speed while chain brake is engaged.
3. Use the chain brake only in starting the engine or in emergencies.
4. Never use throttle latch for cutting.  
Use it only when starting the engine.

### **NOTE**

Do not pull starter rope out to the maximum position.  
Do not allow starter handle to snap back against the casing.

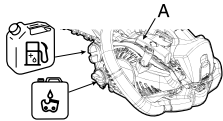

A: Starter handle

- Fill the fuel tank with fuel mixture.  
It is not permitted to fill fuel above the shoulder level of fuel tank.
- Fill the chain oil tank with lubricant.

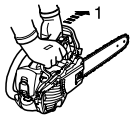

1. Chain brake ACTIVATED position
- Press hand guard forward.  
(Chain brake ACTIVATED position)

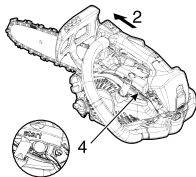

2. Ignition switch (Run)
  3. Choke control knob (Close)
  4. Purge bulb (Primer pump)
- Place ignition switch in run position.



- Turn choke control knob anticlockwise (close).
- Push primer pump until fuel is visible in primer pump.

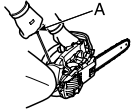

- Securely hold the chain saw.  
When starting the chain saw place the unit on a flat ground and hold the front handle with left hand and hold firmly the rear end of rear handle with right knee and pull starter handle with right hand.
- Make sure guide bar and saw chain are not touching anything when starting the saw.
- Pull starter handle several times until first firing sound is heard.



5. Choke control knob (Open)
  - Turn choke control knob clockwise (open).
  - Pull starter handle until engine starts.
  - Pull throttle lever and the throttle latch will be released.

### Starting the warm engine

1. Chain brake ACTIVATED position
  - Confirm there is fuel and chain oil in the tanks.
  - Press hand guard forward.  
(Chain brake ACTIVATED position)
  - Place ignition switch in run position.

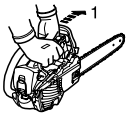

- Securely hold the chain saw.
- Pull starter handle.
- Choke may be used if necessary, but after first firing sound pull throttle trigger a little to release throttle latch and choke.  
After choke control knob is turned and then knob is returned to original position, throttle remains a little open (latch condition).

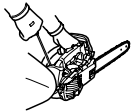

### Running

1. Chain brake RELEASED position
2. Throttle trigger lockout
3. Throttle trigger
  - After engine starts, allow it to idle for a few minutes.
  - Pull front hand guard towards the operator immediately.  
(Chain brake RELEASED position)

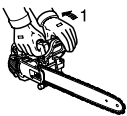

- Squeeze throttle trigger gradually to increase engine revolution.
- The chain starts moving when the engine reaches 4400 r/min approximately.
- Ensure proper acceleration and lubrication of saw chain and guide bar.
- Do not run the engine at high speed unnecessarily.
- Be sure that saw chain stops moving when throttle trigger is released.

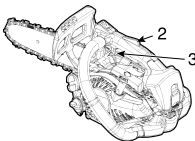

## Stopping the engine

### NOTE

If engine does not stop, turn choke control knob anticlockwise to stop engine. Return the unit to your authorized dealer to check and repair ignition switch before starting the engine again.

1. Throttle trigger
2. Ignition switch

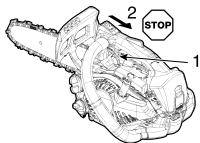

- Release throttle trigger and allow engine to idle.
- Place ignition switch in STOP position.

## Checking chain tension

### ⚠ WARNING

Make sure that the engine is shut off when checking chain tension.

### NOTE

Always loosen clutch cover nut before turning the chain tension adjuster, otherwise the clutch cover and tensioner will be damaged.

- Chain tension should be checked frequently during work and corrected if necessary.
- Tension the chain as tight as possible, but so it can still be pulled easily along the bar by hand.

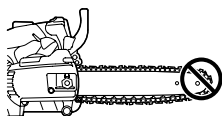

## Chain lubrication test

- Hold the chain just above a dry surface and open the throttle to half speed for 30 seconds.  
A thin line of "thrown" oil should be seen on the dry surface.

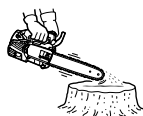

## Pre cutting test

- Familiarize yourself with your chain saw before you start actual cutting.
- For this purpose it may be wise to practice by cutting some small logs or limbs several times.
- Do not allow either people or animals into the work area.  
Multiple operators - Keep a safe distance between two or more operators when working together simultaneously.

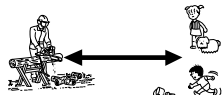

## Correct use of chain brake

### DANGER

Kickback motion is very hazardous.

If the tip of the bar touches wood or the like, the guide bar kicks back in an instant.

The chain brake reduces the possibility of injury due to kickback.

Always check that chain brake works properly before use.

### NOTE

- For practice, while cutting a small tree, push the front guard forward to engage the brake.
- At all times, confirm whether the brake works properly before each task.
- If the chain brake is clogged with wood chips, function of the brake deteriorates a little. Always keep the device clean.
- Do not increase engine revolutions while the chain brake is engaged.
- Chain brake is used in emergencies. Do not use it unless absolutely necessary.
- When using throttle latch at starting, keep the chain brake in position. And after starting the engine, release the brake immediately.
- Never test the brake in an area where petrol fumes are present.

### Chain brake

The chain brake's function is to stop chain rotation after a kickback.

It neither prevents nor reduces kickback.

Do not depend on the chain brake for protection against kickback.

Even with a chain brake, depend on your own good sense and proper cutting methods just as though there were no chain brake.

Even with normal use and proper maintenance, the response time of the brake may lengthen.

The following may interfere with the brake's ability to protect the operator:

- Saw wrongly held too close to operator's body. Kickback time may be too fast even for a perfectly maintained brake to work in time.
- The operator's hand may not be in position to contact the hand guard. Brake will not be tripped.
- Lack of proper maintenance lengthens the brake's stopping time, making it less effective.
- Dirt, grease, oil, pitch, etc. getting into the working parts of the mechanism may lengthen the stopping time.
- Wear and fatigue of the activating brake spring, and wear of the brake / clutch drum and pivot points may lengthen the brake's stopping time.
- A damaged hand guard and lever may render the brake inoperative.



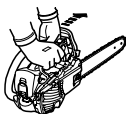

### Checking the brake function of the brake

1. Place the chain saw on the ground.
2. Hold the handle with both hands and accelerate the engine to high speed by using the throttle trigger.
3. Operate the chain brake by turning your left wrist against the front hand guard whilst gripping the front handle.
4. The chain stop immediately.
5. Release the throttle trigger.

If the chain does not stop immediately, take the saw to your dealer to repair.

### Release the chain brake

- When front hand guard is fully pulled towards the operator, chain brake is released.

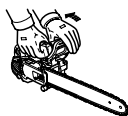

### Non-manual chain brake

#### IMPORTANT

When checking the operation of the non-manual chain brake, use a soft surface substance like wood to provide the impact so the saw chain is not damaged.

- 1). **End of the guide bar** may be placed at the height about 40 cm.
- 2). **Rear handle** should be gripped lightly with the right handle.

The non-manual chain brake stops the operation of the saw chain in such a manner that the kickback action produced at the end of the guide bar non-manually actuates the chain brake. To make sure that the non-manual chain brake operates properly, proceed as follows:

1. **Stop the engine of the chain saw.**
2. Operate the front and rear handles with hands (grip them lightly), so that the guide bar may be placed at the height of about 40 cm as shown in Fig.
3. Softly detach the left hand from the front handle, and touch the end of the guide bar against the wood or the like placed below so that the machine receives an impact. (\* at this time the rear handle should be gripped lightly with right hand)
4. The impact is transferred to the brake lever, which actuates the chain brake.

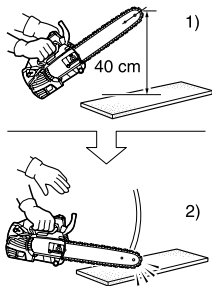

## Cutting instruction

### DANGER

**Do not let the nose or tip of the guide bar touch anything while engine is running to avoid kickback.**

#### General

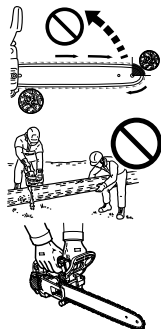

In all circumstances the operation of the chain saw is a one-man job.

It is difficult at times to take care of your own safety, so don't assume the responsibility for a helper as well.

After you have learned the basic techniques of using the saw, your best aid will be your own good common sense.

The accepted way to hold the saw is to stand to the left of the saw with your left hand on the front handle so you can operate the throttle trigger with your right index finger.

Before attempting to fell a tree, cut some small logs or limbs.

Be thoroughly familiar with the controls and the responses of the saw.

Start the engine, see that it is running properly.

Squeeze the trigger to open the throttle wide open, then start the cut.

It is not necessary to press down hard to make the saw cut.

If the chain is properly sharpened, the cutting should be relatively effortless.

Pushing the saw too hard will slow the engine and cutting will actually be more difficult.

Some material may adversely affect the housing of your chain saw.

(Example: palm tree acid, fertilizer etc.)

To avoid housing deterioration carefully remove all packed saw dust around clutch and guide bar area and wash with water.



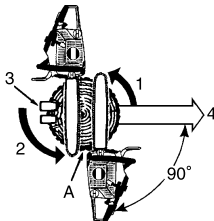
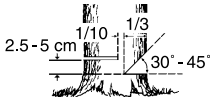
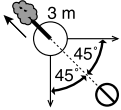

## Felling a tree

A falling tree can seriously damage anything it may hit - a car, a house, a fence, a power-line or another tree.

There are ways to make a tree fall where you want it, so first decide where that is!

Before cutting, clear the area around the tree.

You will need good footing while working and you should be able to work the saw without hitting any obstacles.

### Next select a path of retreat.

When the tree begins to fall you should retreat away from the direction of fall at a 45-degree angle and at least 3 m from the trunk to avoid the trunk kicking back over the stump.

### Begin the cut on the side to which the tree is to fall.

- Notch: 1/3 of diameter and 30° to 45° angle
- Back cut: 2.5 to 5 cm higher
- Uncut hinge wood: 1/10 of diameter

Cut a notch approximately 1/3 of the way into the tree.

The position of this notch is important since the tree will try to fall "into" the notch.

The felling cut is made on the side opposite the notch.

Make the felling cut by placing spiked bumper 2.5 cm to 5 cm above the bottom of the notch and stop cutting at approximately 1/10 of diameter to the inner edge of the notch in order to leave the uncut portion of the wood as a hinge.

1. Notch cuts
  2. Back cut
  3. Wedges (when room)
  4. Fall
- A: Leave 1/10 of diameter hinge

Do not try to cut through to the notch with the felling cut.

The remaining wood between the notch cut and felling cut will act as a hinge when the tree falls, guiding it in the desired direction.

When the tree starts to fall, stop the engine, place the saw on the ground and make your retreat quickly.

## Limbing

### **WARNING**

Limbing in the proximity of power line can result in electrocution.  
Always switch off power supply before starting operation.

### **CAUTION**

Don't saw above chest height.

Limbing a fallen tree is much the same as bucking.  
Never remove a limb from a tree while it is supporting your weight.  
Be careful of the tip touching other limbs.  
Always use both hands.

Don't cut with the saw overhead or the bar in a vertical position.

If the saw should kickback, you may not have good enough control to prevent possible injury.



#### Know how limb is stressed

1. Leave supporting limbs till last.
2. Slide support logs under trunk.
3. If you have thick branches, work from the outside to the inside to avoid your bar and chain get stuck.

Even when limbing, use of the spiked bumper makes it easy to control the chain saw and lessens kickback.

## Bucking

### **CAUTION**

Stay on the uphill side of logs.

Bucking is the sawing of a log or fallen tree into smaller pieces.  
There are a few basic rules which apply to all bucking operations.  
Keep both hands on the handles at all times.  
Support logs if possible.

When cutting on a slope or hillside, always stand uphill.



No standing on log.

## Tension and compression in timber

### WARNING

Never use throttle latch for cutting jobs.

### CAUTION

If you have misjudged the effects of tension and compression, and cut from the wrong side, the timber will pinch the guide bar and chain, trapping it.

Racing the engine with the chain jammed will burn out your clutch.

If the chain should become jammed and the saw can not be removed from the cut do not force it out.

Stop the saw, force a wedge into the cut to open it up.

Never force the saw when it is jammed.

Do not force the saw into the cut.

A dull chain is unsafe and will cause excessive wear to the cutting attachments.

A good way to tell when the chain is dull is when fine saw dust comes out instead of chips.

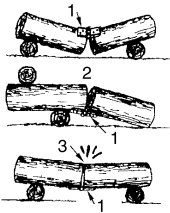

1. Hinge
2. Opened
3. Closed

A length of timber lying on the ground will be subject to tension and compression, depending on at which points the major support is.

When timber is supported at its ends the compression side is at the top and the tension side is at the bottom.

To cut between these support points, make the first cut downwards approximately 1/3rd the timber diameter.

The second cut is made upwards and should meet the first cut.

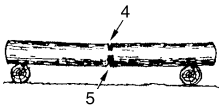

#### Heavy stress

4. 1/3 diameter. To avoid split.
5. Weakening cut to finish.

When the timber is supported at one end only, make the first cut upwards approximately 1/3rd the timber diameter.

The second cut is made downwards and should meet the first cut.

#### Overbuck

6. Down
7. Unsupported end

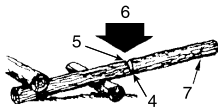

#### Underbuck

8. Up

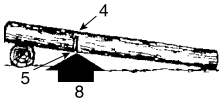

9. Wedge

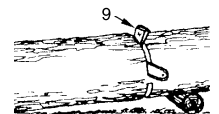

Make angled cut when one section may settle against the other.



## Service maintenance guide

Area	Maintenance	Page	Before use	Monthly
Air filter	Clean / Replace	31	•	
Fuel system	Inspect	31	•	
Fuel filter	Inspect / Clean / Replace	31	•	
Oil filter	Inspect / Clean / Replace	31	•	
Spark plug	Inspect / Clean / Adjust / Replace	31		•
Cooling system	Inspect / Clean	33	•	
Guide bar	Inspect / Clean	32	•	
Sprocket / Clutch drum	Inspect / Replace	32	•	•
Carburettor	Adjust / Replace and adjust	32		•
Silencer	Inspect / Tighten / Clean	33	•	
Chain brake	Inspect / Replace	21	•	
Starter	Inspect	28	•	
Screws, bolts and nuts	Inspect, Tighten / Replace	-	•	

### WARNING

⚠ If not maintained properly, the product may pose a serious risk to physical health.

### CAUTION

⚠ Before and after using the product, check the antivibration rubber or spring for making sure that it is not worn, cracked, or deformed.

### NOTE

If not maintained properly, the product's performance may deteriorate.

### IMPORTANT

Time intervals shown are maximum.

Actual use and your experience will determine the frequency of required maintenance.

If your saw is subjected to high loads due to a fall or impact, inspect each part.

If you continuously use vegetable based chain oil, inspect and do maintenance often.

When you find anything wrong, ask your dealer for repair.

## Troubleshooting

Trouble		Cause	Remedy
Engine	- hard to start - does not start		
Engine cranks	Fuel at carburettor    Not fuel at carburettor	<ul style="list-style-type: none"> <li>• Fuel filter clogged</li> <li>• Fuel line clogged</li> <li>• Carburettor</li> </ul>	<ul style="list-style-type: none"> <li>• Clean or replace</li> <li>• Clean</li> <li>• Ask your dealer</li> </ul>
	Fuel at cylinder    No fuel at cylinder	<ul style="list-style-type: none"> <li>• Carburettor</li> </ul>	<ul style="list-style-type: none"> <li>• Ask your dealer</li> </ul>
	Silencer wet with fuel	<ul style="list-style-type: none"> <li>• Fuel mixture is too rich</li> </ul>	<ul style="list-style-type: none"> <li>• Open choke</li> <li>• Clean / replace air filter</li> <li>• Adjust carburettor</li> <li>• Ask your dealer</li> </ul>
	Spark at end of plug wire    No spark at end of plug wire	<ul style="list-style-type: none"> <li>• Ignition switch off</li> <li>• Electrical problem</li> </ul>	<ul style="list-style-type: none"> <li>• Turn switch on</li> <li>• Ask your dealer</li> </ul>
	Spark at plug    No spark at plug	<ul style="list-style-type: none"> <li>• Spark gap incorrect</li> <li>• Covered with carbon</li> <li>• Fouled with fuel</li> <li>• Spark plug defective</li> </ul>	<ul style="list-style-type: none"> <li>• Adjust 0.6 to 0.7 mm</li> <li>• Clean or replace</li> <li>• Clean or replace</li> <li>• Replace plug</li> </ul>
Engine does not crank		<ul style="list-style-type: none"> <li>• Internal engine problem</li> </ul>	<ul style="list-style-type: none"> <li>• Ask your dealer</li> </ul>
Engine runs	Dies or accelerates poorly	<ul style="list-style-type: none"> <li>• Air filter dirty</li> <li>• Fuel filter dirty</li> <li>• Fuel vent plugged</li> <li>• Spark plug</li> <li>• Carburettor</li> <li>• Cooling system plugged</li> <li>• Exhaust port / silencer plugged</li> </ul>	<ul style="list-style-type: none"> <li>• Clean or replace</li> <li>• Clean or replace</li> <li>• Clean</li> <li>• Clean and adjust / replace</li> <li>• Adjust</li> <li>• Clean</li> <li>• Clean</li> </ul>
Rotating saw chain at idling speed		<ul style="list-style-type: none"> <li>• Carburettor</li> <li>• Clutch damaged or binded</li> </ul>	<ul style="list-style-type: none"> <li>• Ask your dealer</li> <li>• Ask your dealer</li> </ul>

### **WARNING**

- ♦ All chain saw service operations, other than items listed in the Operator's Manual, should be performed by competent service personnel.
- ♦ Fuel vapors are extremely flammable and may cause fire and / or explosion. Never test for ignition spark by grounding spark plug near cylinder plug hole, otherwise serious personal injury may result.

### **NOTE**

When starter grip cannot be pulled lightly, the trouble is diagnosed as failure of engine inside. Please consult your dealer.  
If disassembled inadvertently, it can cause injury.

## Saw chain maintenance

### **WARNING**

Switch off the engine before sharpening the chain.  
Always wear gloves when working on chain.

### **CAUTION**

The following faults will increase the risk of kickback considerably.

- 1) Top plate angle too large
- 2) File diameter too small
- 3) Depth gauge too large

### **NOTE**

These angles are referred to as Oregon 25A, 25AP, 91PX and SUGIHARA A4S, Carlton N1C-BL saw chains.

For other branded saw chain, follow it's chain manufacturer's instruction.

- Properly filed cutters are shown below.

A: Top plate angle N1C-BL; 35°, 25A, 25AP, 91PX and A4S; 30°

B: Top plate cutting angle N1C-BL; 60°, 25A, 25AP, 91PX and A4S; 55°

C: Depth gauge N1C-BL; 0.56 mm, 25A, 25AP, and 91PX; 0.65 mm, A4S; 0.5 mm

D: Parallel

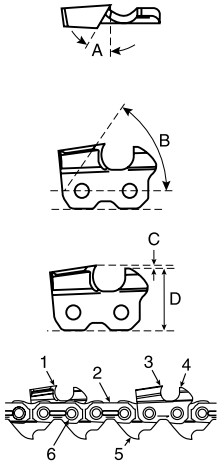

1. Left hand cutter
2. Tie strap
3. Right hand cutter
4. Depth gauge
5. Drive link
6. Rivet

Never operate a chain saw with a dull or damaged chain.

If the chain requires excessive pressure to cut or produces dust instead of wood chips then inspect the cutters for damage.

When sharpening the chain the objective will be to maintain the same angles and profiles throughout its life as when it was new.

Inspect the chain for damage or wear every time you refuel your chain saw.

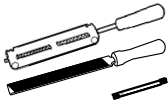

• Sharpening

In order to file the chain correctly you need: round file and file holder, flat file and a depth gauge tool.

By using the correct file size (A4S; 3.5 mm Round file, other; 4.0 mm Round file) and a file holder, it is easier to receive a good result.

Consult your dealer for correct sharpening tools and sizes.

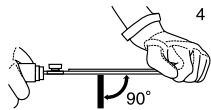
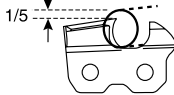
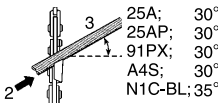
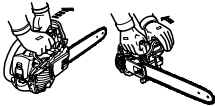

1. Lock the chain - push the front hand guard forward.  
To rotate the chain - pull the front hand guard against front handle.
2. Your chain will have alternative left and right hand cutters.  
Always sharpen from the inside out.
3. Keep the angle lines of the file holder parallel to the line of the chain and file the cutter back until the damaged area (side plate and top plate) has been removed.
4. Hold the file horizontally.
5. Avoid touching the tie straps with the file.
6. Sharpen the most damaged cutter first and then take all the other cutters back to the same length.
7. The depth control determines the thickness of wood chip produced and must be maintained correctly throughout the chain life.
8. As the cutter length is reduced, the depth control height is altered and must be reduced.
9. Position the depth gauge, and file off any of the depth control which protrudes.
10. Round off the front of the depth control to allow smooth cutting.
11. Drive link serves to remove sawdust from the groove of the guide bar.  
Therefore, keep the lower edge of the drive link sharp.

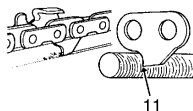
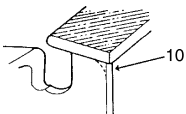
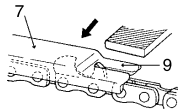

When setting of the chain is finished, soak it in oil and wash away filings completely before using.

When the chain has been filed on the bar, supply sufficient oil to it, and rotate the chain slowly to wash away the filings before using again.

If the chain saw is operated with filings clogged in the groove, the saw chain and the guide bar will be damaged prematurely.

If the saw chain becomes soiled with resin for instance, clean it with kerosene and soak it in oil.

## Service

- If you have any questions or problems, please contact your dealer.

### Air filter

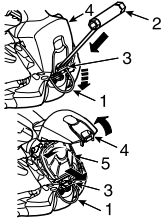

1. Lifting hook
2. T-wrench
3. Cleaner cover latch
4. Air cleaner cover
5. Air filter

- Check before every use.
- Close choke.
- Raise the lifting hook, and towards the lower end.
- Release the cleaner cover latch with T-wrench, and remove the air cleaner cover and the air filter.  
Brush off dust lightly, or wash it in a non-inflammable solvent if necessary, or replace the air filter.
- Dry it completely before installation.
- Reinstall the air filter and cover, engage latch and return the lifting hook.

### Check fuel system

- Check before every use.
- After refuelling, make sure fuel does not leak or exude from around fuel pipe, fuel grommet or fuel tank cap.
- In case of fuel leakage or exudation there is a danger of fire.  
Stop using the machine immediately and request your dealer to inspect or replace.

### Fuel filter

## DANGER

**Petrol and fuel are extremely flammable.  
Extreme caution is required when handling petrol or fuel.**

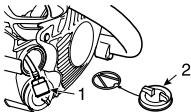

1. Fuel filter
  2. Fuel tank cap
- Check periodically.
    - Do not allow dust to enter fuel tank.
    - A clogged filter will cause difficulty in starting engine or abnormalities in engine performance.
    - Pick up the fuel filter through fuel inlet port with a piece of steel wire or the like.
    - When the filter is dirty, replace it.
    - When the inside of the fuel tank is dirty, it can be cleaned by rinsing the tank out with petrol.

### Oil filter



1. Oil filter
  2. Oil tank cap
- Check periodically.
    - Do not allow dust to enter oil tank.
    - A clogged oil filter will affect the normal lubricating system.
    - Pick it up through oil filling hole with a piece of steel wire or the like.
    - If the filter is dirty, wash it in petrol or replace it.
    - When the inside of the oil tank gets dirty, it can be cleaned by rinsing the tank out with petrol.

### Spark plug

- \* Spark plug gap: 0.6 to 0.7 mm
- Check periodically.  
The standard spark plug is 0.6 to 0.7 mm





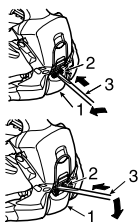

## Spark plug cover

1. Spark plug cover
2. Spark plug cover latch
3. T-wrench

- Release the spark plug cover latch with T-wrench.
- Inspect the spark plug, clean or replace if damaged.
- Reinstall the spark plug and cover, engage latch with T-wrench.

## Guide bar

### NOTE

When replacing guide bar or saw chain, ask your dealer.

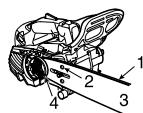

1. Groove
2. Oil hole
3. Guide bar
4. Sprocket

- Clean before using.
  - Clean the groove of the guide bar with a small screw driver, for example.
  - Clean oil holes with a wire.
- Reverse guide bar periodically.
- Check sprocket and the clutch and clean the bar mount area before installation of the guide bar.
  - Replace either or both if worn.

## Sprocket / Clutch drum

- \* Worn out: 0.5 mm
- The damaged sprocket will cause premature damage or wear of saw chain.
  - When the sprocket has worn out 0.5 mm or more, replace it.
- Check sprocket when you install new chain.
  - Replace it if worn.
- Check clutch drum, if it rotates freely and smoothly.
  - If not, ask your dealer for repair.

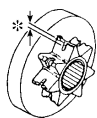

## Carburettor

### ⚠ CAUTION

**When starting, idle speed adjuster (T) should be adjusted not to rotate the saw chain. When there is some trouble with the carburettor, contact your dealer.**

- T: Idle speed adjuster
- Do not adjust the carburettor unless necessary.
  - To adjust the carburettor proceed as follows:
    - Start engine and allow it to run at high idle until warm.
    - Turn the idle speed adjuster (T) anticlockwise until the saw chain stops moving.
    - Turn idle speed adjuster (T) anticlockwise an additional 1/2 turn.
    - Accelerate to full throttle to check for smooth transition from idle to full throttle.



## Automatic oiler

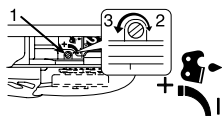

1. Oil adjusting screw
2. Decrease
3. Increase

- The discharge volume of the automatic oiler is adjusted to 6 mL/min approximately at 7000 r/min, prior to shipment from factory.
  - To increase the delivery volume, turn the adjusting screw anticlockwise. When the adjusting screw touches stopper and stops, this position indicates maximum discharge volume. (13 mL/min at 7000 r/min)
  - Do not turn the adjusting screw beyond the maximum or minimum limit of volume adjustment.

## Cylinder fins (Cooling system)

### NOTE

If you use the unit with the condition of being clogged by dirt or dust, it may cause breakage of the unit or melting damage of covers around silencer.  
If you are not able to remove the dirt or dust, ask your dealer.

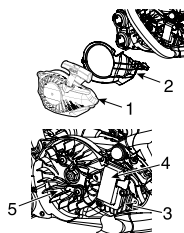

1. Recoil starter
2. Air guide plate
3. Cylinder fins
4. Ignition coil
5. Flywheel magneto

- Use a wood or plastic scraping tool and a soft brush to remove dirt and dust.
- Check periodically.
- Remove the recoil starter and the air guide plate.
- Remove dirt and dust from the recoil starter and the air guide plate.
- Clogged fins will result in poor engine cooling.
- Remove dirt and dust from between fins to let cooling air pass easily.
- Clean the periphery of the ignition coil and the flywheel magneto.
- Assemble the components in reverse order.

## Silencer

### NOTE

Carbon deposits in silencer will cause drop in engine output.  
The spark arrester screen must be checked periodically.

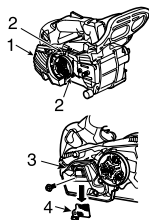

1. Silencer cover
2. Two bolts
3. Silencer
4. Spark arrester screen

Remove two bolts and the silencer cover.

- Remove the spark plug lead.
- Remove the spark arrester screen from the silencer body.
- Clean carbon deposits from the silencer components.
- Replace the screen if it is cracked, or has holes burned through.
- Assemble the components in reverse order.

## Replacement guide bar and chain

### IMPORTANT

- Only use replacement bars and chains specified by the manufacture or the equivalent. Otherwise, there may be a risk of accidents and damage to the machine.

## Storage

### Long term storage (Over 30 days)

#### WARNING

Do not store in an enclosure where fuel fumes may accumulate or reach an open flame or spark.

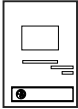

#### NOTE

For future reference, you should keep this operator's manual.

Do not store your unit for a prolonged period of time (30 days of longer) without performing protective storage maintenance which includes the following:

1. Drain the fuel tank completely and pull the recoil starter handle several times to remove fuel from the carburettor.
2. Always store fuel in approved container.
3. Place the ignition switch in the "STOP" position.
4. Remove accumulation of grease, oil, dirt and debris from exterior of unit.
5. Perform all periodic lubrication and services that are required.
6. Tighten all the screws, bolts and nuts.
7. Remove the spark plug and pour 10 mL of fresh, clean, two-stroke engine oil into the cylinder through the spark plug hole.
  - A. Place a clean cloth over the spark plug hole.
  - B. Pull the recoil starter handle 2 or 3 times to distribute the oil inside the cylinder.
  - C. Observe the piston location through the spark plug hole.

Pull the recoil starter handle slowly until the piston reaches the top of its travel and leave it there.
8. Install the spark plug (Do not connect ignition cable).
9. Cover the chain and the guide bar with the guide bar cover before putting them in storage.
10. Store unit in a dry, dust free place, out of the reach of children and other unauthorized persons.

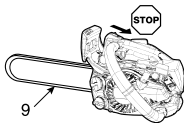

## Disposal procedure



- Dispose of waste oil in accordance with local regulations.
- Major plastic parts making up the product have codes showing their materials. The codes refer to the following materials; dispose of those plastic parts in accordance with local regulations.

Mark	Material
>PA6-GF<	Nylon 6 - Glass fibre
>PA66-GF<	Nylon 66 - Glass fibre
>PP-GF<	Polypropylene - Glass fibre
>PE-HD<	Polyethylene
>POM<	Polyoxymethylene

- Please contact your dealer in case you do not know how you should dispose of waste oil / plastic parts.



## DICHIARAZIONE DI CONFORMITÀ CE

(Ai sensi della direttiva macchine 2006/42/CE Allegato II parte 1.A)

**VINCO S.r.l. - Piazza Statuto 1 - 14100 Asti**

dichiara sotto alla propria responsabilità, che la seguente macchina, identificata come:

Denominazione, funzione, tipo: motosega

Modello: TCS2510

Marca: HYUNDAI

Numero serie: N/A

Mese e anno di fabbricazione: gennaio 2022

soddisfa i pertinenti requisiti delle seguenti Direttive:

Direttiva Macchine 2006/42/CE

EMC 2014/30/UE

Livello di potenza acustica garantito  $L_{WA} = 115$  dB

Potenza netta installata: 1 kW

Norme armonizzate:

EN 2014/30/EU

EN ISO 12100:2010

EN ISO 11681-2:2011

Persona autorizzata a costituire il fascicolo tecnico: Sig. Daniele Nossa, presso Vinco s.r.l.,  
Piazza Statuto 1 - 14100 Asti, Italia.

Asti, 06/12/2021

Luogo e data

Legale rappresentante (Lidio Conti)

# **CERTIFICATO DI GARANZIA**

**Vinco s.r.l. - P.zza Statuto,1 - 14100 Asti - Italy**

Modello: \_\_\_\_\_ Codice: \_\_\_\_\_

Data di acquisto \_\_\_\_\_

## **QUESTO CERTIFICATO NON DEVE ESSERE SPEDITO MA CONSERVATO UNITAMENTE ALL'IMBALLO ORIGINALE**

La garanzia ha validità soltanto se corredata da **RICEVUTA FISCALE**,  
Vi consigliamo quindi di allegarla al presente certificato di garanzia.

La garanzia ha valore per un periodo di 2 anni dalla data di acquisto (un anno in caso di beni strumentali) e viene comprovata da un documento valido agli effetti fiscali, rilasciato dal venditore autorizzato, riportante la ragione sociale dello stesso e la data in cui è stata effettuata la vendita. Affinché la garanzia sia operativa, è necessario che il certificato di garanzia sia conservato unitamente ad uno dei documenti validi agli effetti fiscali riportante gli estremi identificativi del prodotto, e che entrambi siano esibiti in caso di intervento da parte di personale tecnico dei Centri Assistenza Autorizzati.

Questo certificato di garanzia si riferisce alle condizioni di Garanzia Convenzionali del Produttore nei confronti del Consumatore e non pregiudica i diritti della Garanzia Europea (previsti dalla Dlgs 206/2005 Codice del Consumo).

Per fruire del servizio di assistenza tecnica in garanzia, il consumatore può:

1. recarsi presso il punto vendita senza alcuna incombenza ulteriore; 2. richiedere il servizio aggiuntivo di assistenza con ritiro a domicilio. Il servizio è aggiuntivo e non sostitutivo rispetto a quello di cui al punto 1 e si applica solo alle tipologie di prodotti previste da Vinco. Invitiamo a contattare Vinco allo scopo di verificare se il prodotto possa usufruire di questo servizio.

All'interno del periodo di garanzia, Vinco S.r.l. si impegna a sostituire o riparare gratuitamente le parti componenti l'apparecchio che risultino difettose all'origine per vizi di fabbricazione, senza alcuna spesa per il consumatore.

Non sono coperte dalla garanzia tutte le parti che dovessero risultare difettose a cause di negligenza o trascuratezza nell'uso (mancata osservanza delle istruzioni per il funzionamento dell'apparecchio), errata installazione o manutenzione, manutenzione operata da personale non autorizzato, danni da trasporto, ovvero di circostanze che, comunque, non possono farsi risalire a difetti di fabbricazione dell'apparecchio. Sono esclusi dalle prestazioni in garanzia gli interventi inerenti l'installazione e l'allacciamento agli impianti di alimentazione nonché le manutenzioni citate nel libretto di istruzioni. Non sono inoltre coperti da garanzia le avarie causate da urti, manomissioni o installazioni improprie.

Questo certificato di garanzia è valido solo se l'apparecchiatura è venduta ed installata sul territorio italiano (compresi la Repubblica di San Marino e la Città del Vaticano). La richiesta di intervento per riparazioni in garanzia verrà evasa con prontezza dagli organi competenti, compatibilmente con le esigenze di carattere organizzativo. Il produttore non potrà comunque rispondere di disagi dipendenti da eventuali ritardi nell'esecuzione dell'intervento. Il consumatore finale dovrà presentare l'apparecchio da riparare in garanzia presso il punto vendita, unitamente al documento fiscale di acquisto ed al certificato di garanzia. Il produttore declina inoltre ogni responsabilità per eventuali danni che possano, direttamente o indirettamente, derivare a persone, cose ed animali domestici in conseguenza della mancata osservanza di tutte le prescrizioni indicate nell'apposito Libretto Istruzioni e concernenti specialmente le avvertenze in tema di installazione, uso e manutenzione dell'apparecchio. Qualora l'apparecchio venisse riparato presso uno dei Centri Assistenza Autorizzati indicati dal produttore, i rischi di trasporto relativi saranno a carico dell'utente nel caso di invio diretto ed a carico del Servizio nel caso di ritiro presso l'utente.

**HYUNDAI**  
POWER PRODUCTS

**Importato e Distribuito da Vinco S.r.l.**  
Pzza Statuto,1 – 14100 Asti (AT) ITALY  
Tel: +39 0141 351284 Fax: +39 0141 351285  
E-mail: [info@vincoasti.it](mailto:info@vincoasti.it) - [www.vincoasti.com](http://www.vincoasti.com)

**CENTRO RICAMBI E ASSISTENZA:**

Viale Giordana, 7 - 10024 Moncalieri (TO) - ITALIA Tel: +39 0141/1766315  
Assistenza e-mail: [assistenza@vincoasti.it](mailto:assistenza@vincoasti.it) - Ricambi: [ricambi@vincoasti.it](mailto:ricambi@vincoasti.it)

MADE IN CHINA