

DOMUS

ISTRUZIONI DI MONTAGGIO CASETTA IN RESINA LEONOR 4X6 COLORE GRIGIO E NERO - 440508

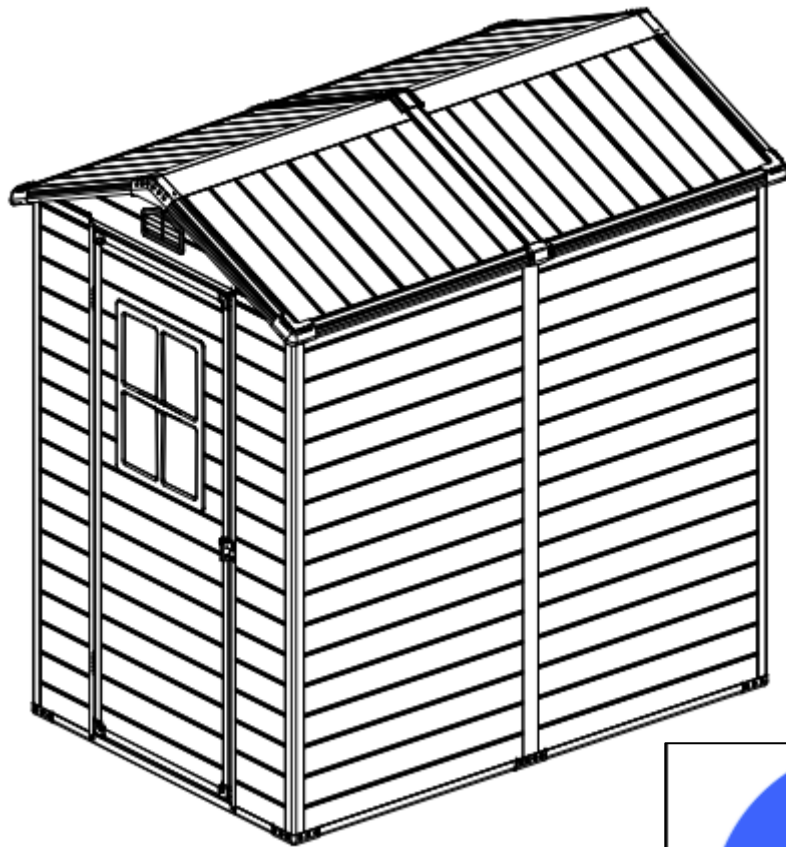

Alcune parti dei pannelli possono risultare taglienti, pertanto si raccomanda la massima cautela nel movimentare le componenti. Si rende obbligatorio l'utilizzo di guanti antitaglio per evitare gravi lesioni. Eventuali incidenti avvenuti per il mancato rispetto di tale prescrizione non sono coperti da garanzia.



INDICE

PRIMA DI INIZIARE	3
LISTA DEI COMPONENTI - COLLO 1/2	4
LISTA DEI COMPONENTI - COLLO 2/2	5
VISIONE D'INSIEME	6
PREASSEMBLAGGIO DELLA BASE	7
PREASSEMBLAGGIO PARETE POSTERIORE	7
PREASSEMBLAGGIO PARETI LATERALI	8
PREASSEMBLAGGIO PARETE FRONTALE	8
PREASSEMBLAGGIO TRIANGOLO SUPERIORE	9
PREASSEMBLAGGIO TETTO	9
PREASSEMBLAGGIO PORTA	10
AVVERTENZE	22

PRIMA DI INIZIARE

Prima dell'installazione, è importante verificare con il proprio comune eventuali autorizzazioni necessarie per il posizionamento della casetta.

Le istruzioni fornite in questo manuale contengono tutte le informazioni necessarie per il corretto assemblaggio della casetta. Leggere attentamente tutte le istruzioni prima di iniziare.









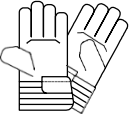

Durante il montaggio, seguire attentamente la sequenza dei passaggi per ottenere risultati corretti.

Attenzione: questo prodotto richiede due persone e circa un giorno intero per il montaggio.

Posizionamento della casetta:

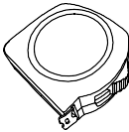
- Evitare la presenza di alberi con rami sporgenti sopra la struttura: le foglie possono richiedere pulizie frequenti e i rami rotti possono rappresentare un pericolo.
- La presenza di piccoli arbusti o recinzioni nelle vicinanze può essere utile, poiché funge da frangivento.
- Il terreno deve essere livellato in tutta la sua superficie. Verificare la planarità utilizzando una livella a bolla.
- La superficie su cui posizionare la casetta può essere realizzata in legno trattato o in cemento, per impedire all'umidità di penetrare all'interno.
- Non montare direttamente la casetta sul prato: in caso di pioggia, il terreno potrebbe diventare fangoso.
- Se si posiziona su una superficie in cemento, assicurarsi che abbia una leggera pendenza verso i bordi per evitare ristagni d'acqua.
- In alternativa, la superficie di base può essere costruita con mattoni o blocchi posati su fondazioni in cemento solide e perfettamente livellate. Il telaio dovrà essere forato e fissato alla base con viti.

Attrezzatura necessaria NON inclusa:













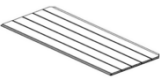

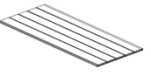
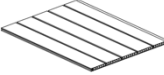

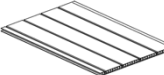
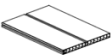
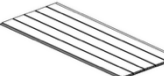
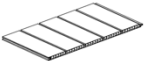

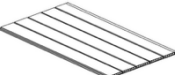

				
Guanti antitaglio	Occhiali di sicurezza	Scarpe	Trapano elettrico	Punte da trapano
				
Cacciavite	Metro a nastro	Chiave inglese	Scala	

Consigli e avvertenze:



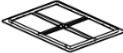























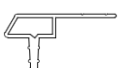

- Liberare l'area di lavoro per consentire l'accesso su 4 lati. Una superficie di lavoro rialzata faciliterà il montaggio.
- Le parti sono tutte indentificate, seguendo le istruzioni pagina per pagina, potrete vedere nei diagrammi dove è posizionata la singola parte.
- **È obbligatorio l'utilizzo di guanti antitaglio, occhiali e scarpe protettive per evitare lesioni accidentali. Alcune parti possono risultare taglienti e pericolose, pertanto si raccomanda la massima cautela nel movimentare i componenti.**
- Tenere i bambini lontani dall'area di lavoro.
- **Non montare la casetta in caso di vento per evitare danni alle parti o lesioni personali. Prestare attenzione in caso di terreno bagnato o fangoso.**
- Disimballare tutti i pezzi e posizionarli all'esterno dell'area di lavoro, verificare la presenza di tutte le parti confrontandole con l'elenco dei componenti che trovate nella pagina successiva.
- Pulire tutti i pezzi di metallo, rivetti e viti.

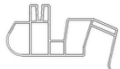

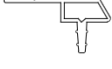
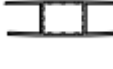



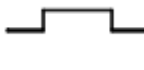

Eurobrico Spa declina ogni responsabilità nel caso in cui l'acquirente non segua pedissequamente le istruzioni di montaggio ed i consigli e avvertenze previsti, munendosi dell'adeguata attrezzatura necessaria; il tutto come indicato nel presente manuale Domus "Istruzioni di Montaggio" che si suggerisce di leggere con attenzione e in maniera completa.

LISTA DEI COMPONENTI - COLLO 1/2

FOTO	CODICE	PEZZI	VERIFICA	FOTO	CODICE	PEZZI	VERIFICA
	A34-C03	1			A64-C33	2	
	A64-C01	1			A64-C34	1	
	A64-C02	2			A64-V4-C01	4	
	A64-C03	1			A64-V4-C02	4	
	A64-C06	2			A64-DW-C01	3	
	A64-C07	6			D03	1	
	A64-C11	12			F35-C27	4	
	A64-C12	1			F35-C29	4	
	A64-C13	2			F35-C30	4	
	A64-C29	2			F35-C31	1	
	A64-C30	2			F35-C32	1	
	A64-C31	2			F35-C33	1	
	A64-C32	2			F35-C34	1	

LISTA DEI COMPONENTI - COLLO 2/2

FOTO	CODICE	PEZZI	VERIFICA	FOTO	CODICE	PEZZI	VERIFICA
	A34-C04	1			A64-C24	2	
	A64-A02	1			A64-C26	1	
	A64-A05	1			A64-C27	2	
	A64-A06	2			A64-V4-A01	1	
	A64-A15	2			A64-V4-A02	1	
	A64-C04	3			A64-V4-A03	4	
	A64-C08	4			A64-V4-A04	2	
	A64-C14	2			A64-V4-A05	2	
	A64-C17	4			A64-V4-A06	1	
	A64-C17-1	4			A64-V4-A07	1	
	A64-C18	4			A86-V4-A01	1	
	A64-C18-1	4			A86-V4-C05	2	
	A64-C19	4			A86-V4-A06	1	
	A64-C21	4			A86-V4-A07	2	
	A64-C22	2			D02	1	

	E01 (ST4.2*13)	20			E07 (ST4.2*55)	4	
	E02 (ST4.2*12)	365			E08 (M6*50)	6	
	E03 (ST4.8*19)	32			E09 (M6*8.5)	6	
	E04 (ST5.5*50)	6			E12 (M4*10)	12	

VISIONE D'INSIEME

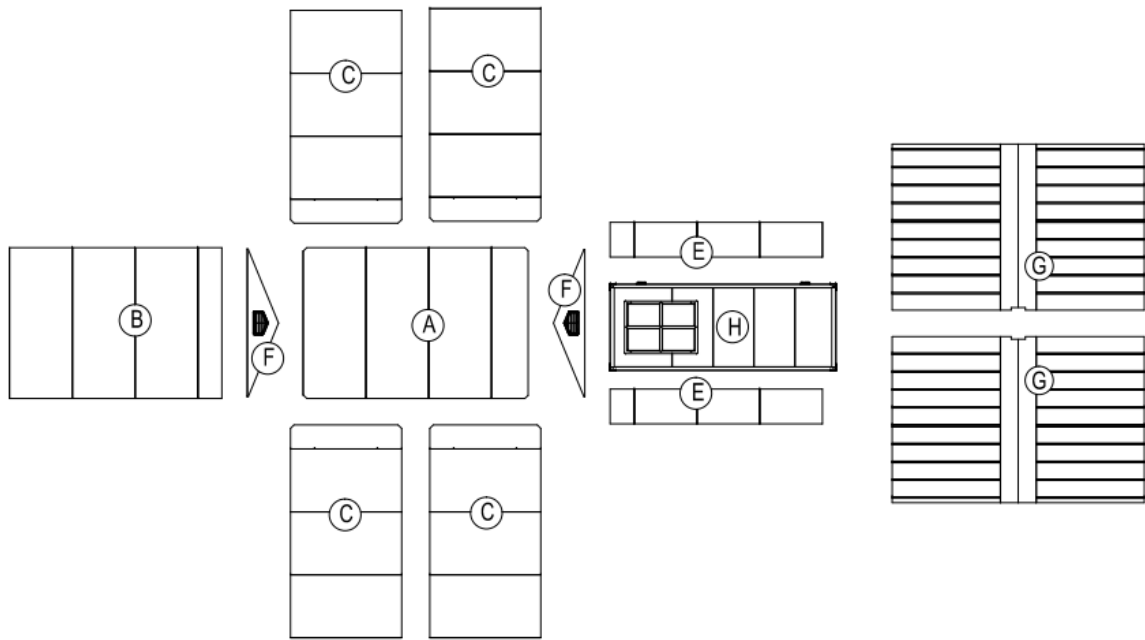

PREASSEMBLAGGIO DELLA BASE

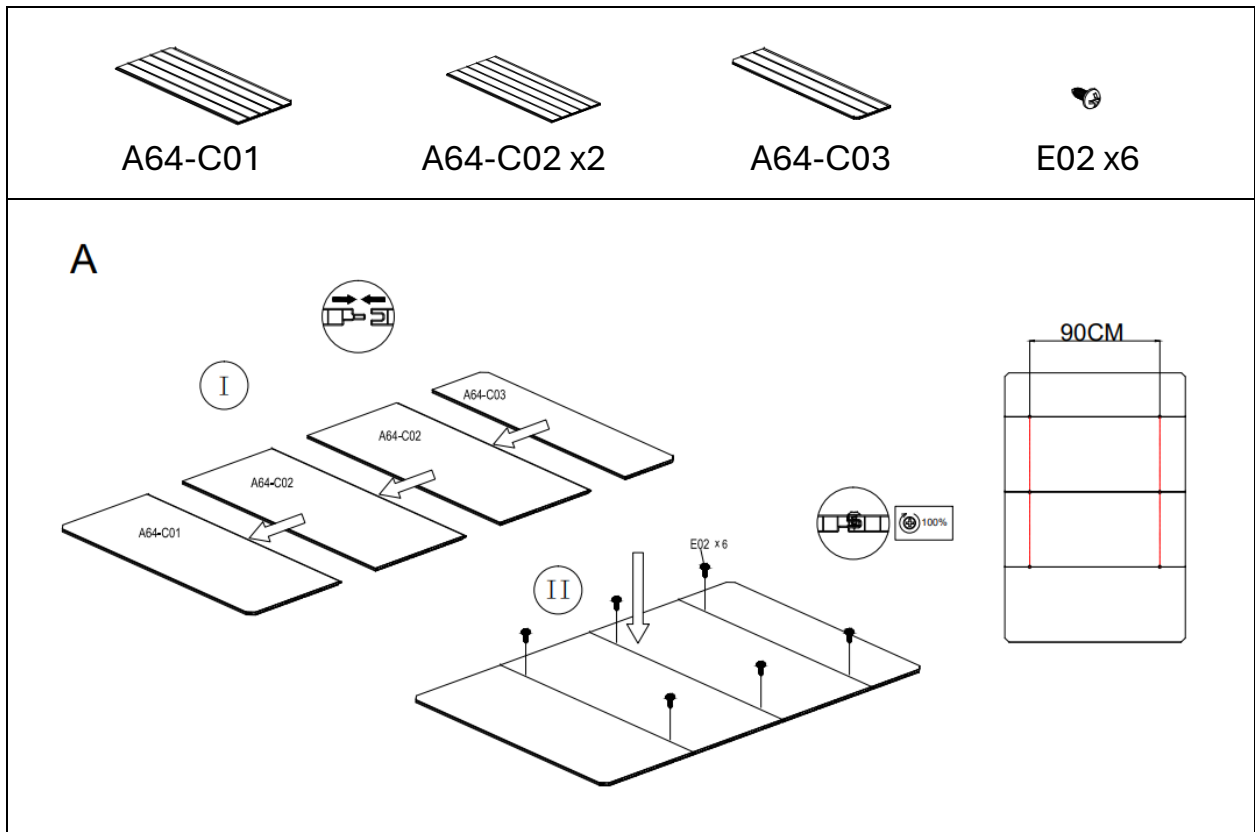

PREASSEMBLAGGIO PARETE POSTERIORE

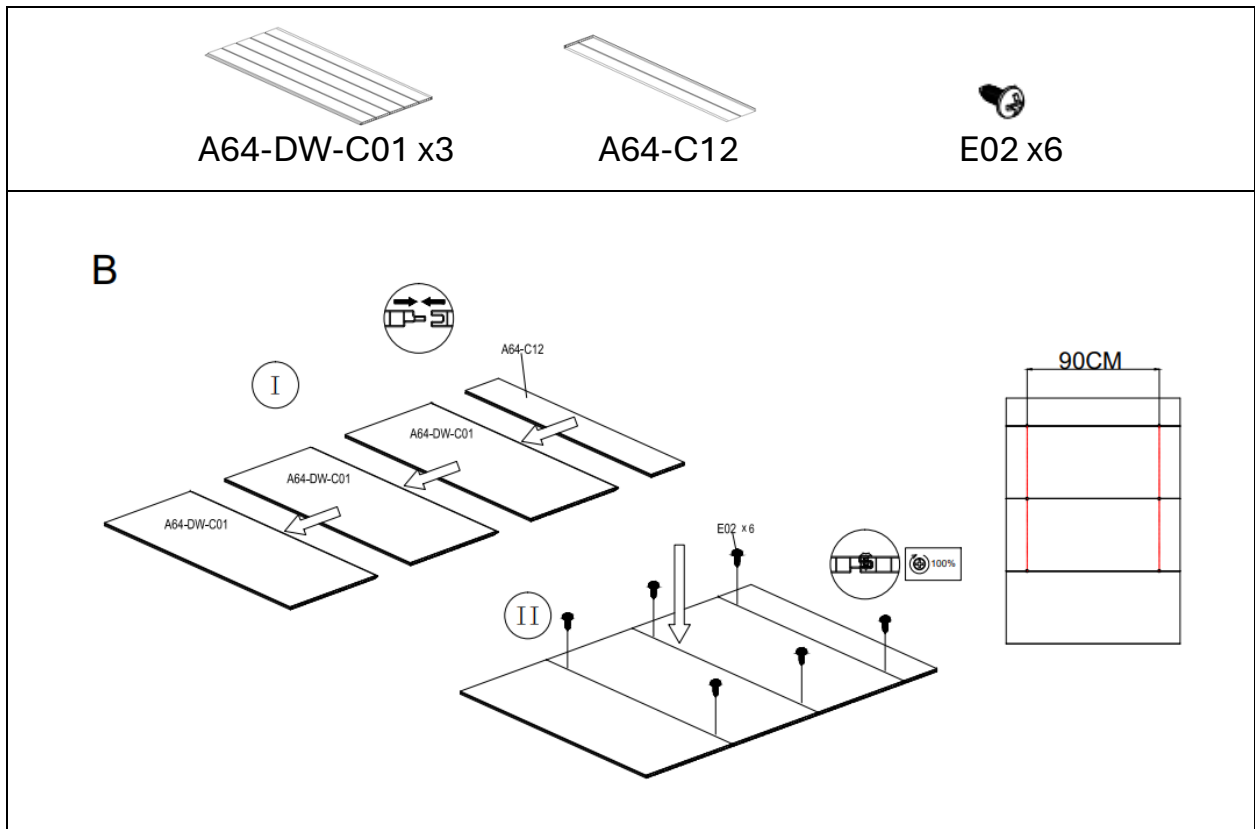

PREASSEMBLAGGIO PARETI LATERALI

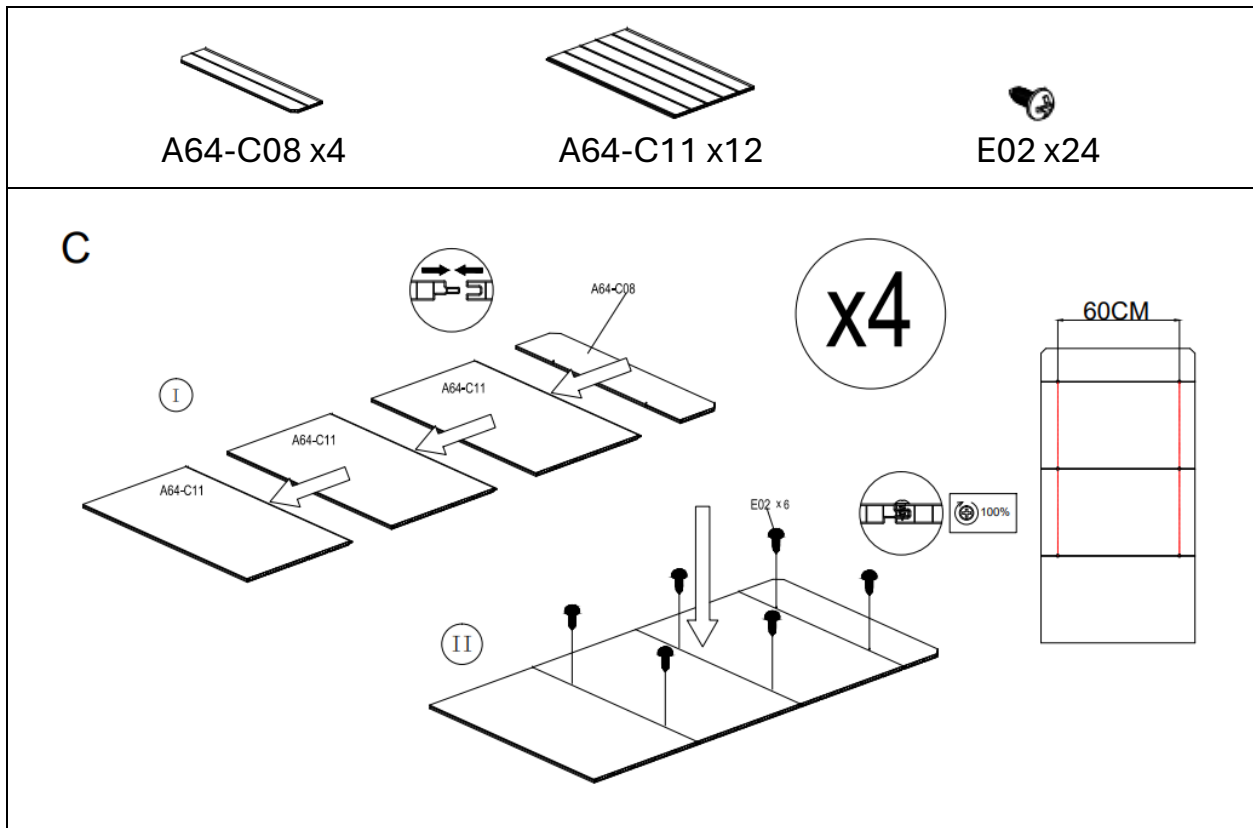

PREASSEMBLAGGIO PARETE FRONTALE

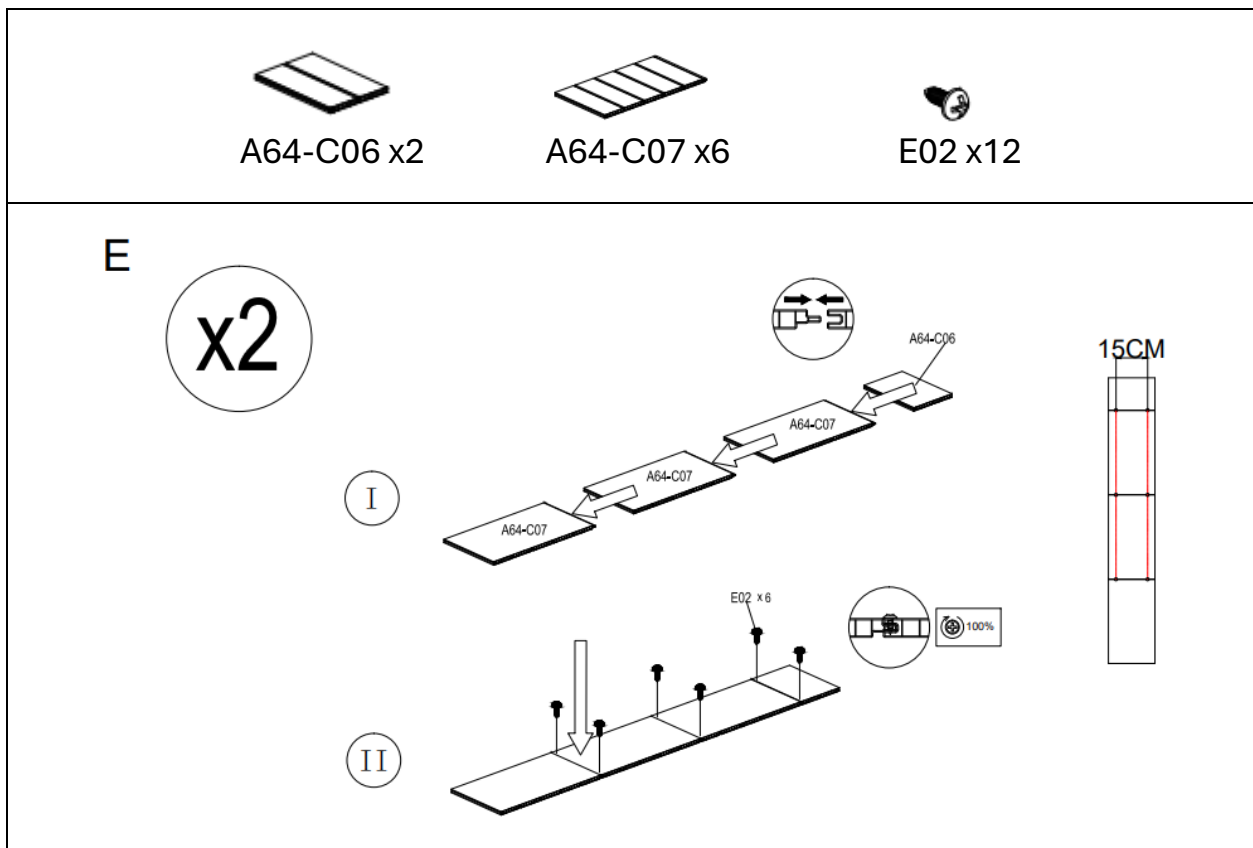

PREASSEMBLAGGIO TRIANGOLO SUPERIORE

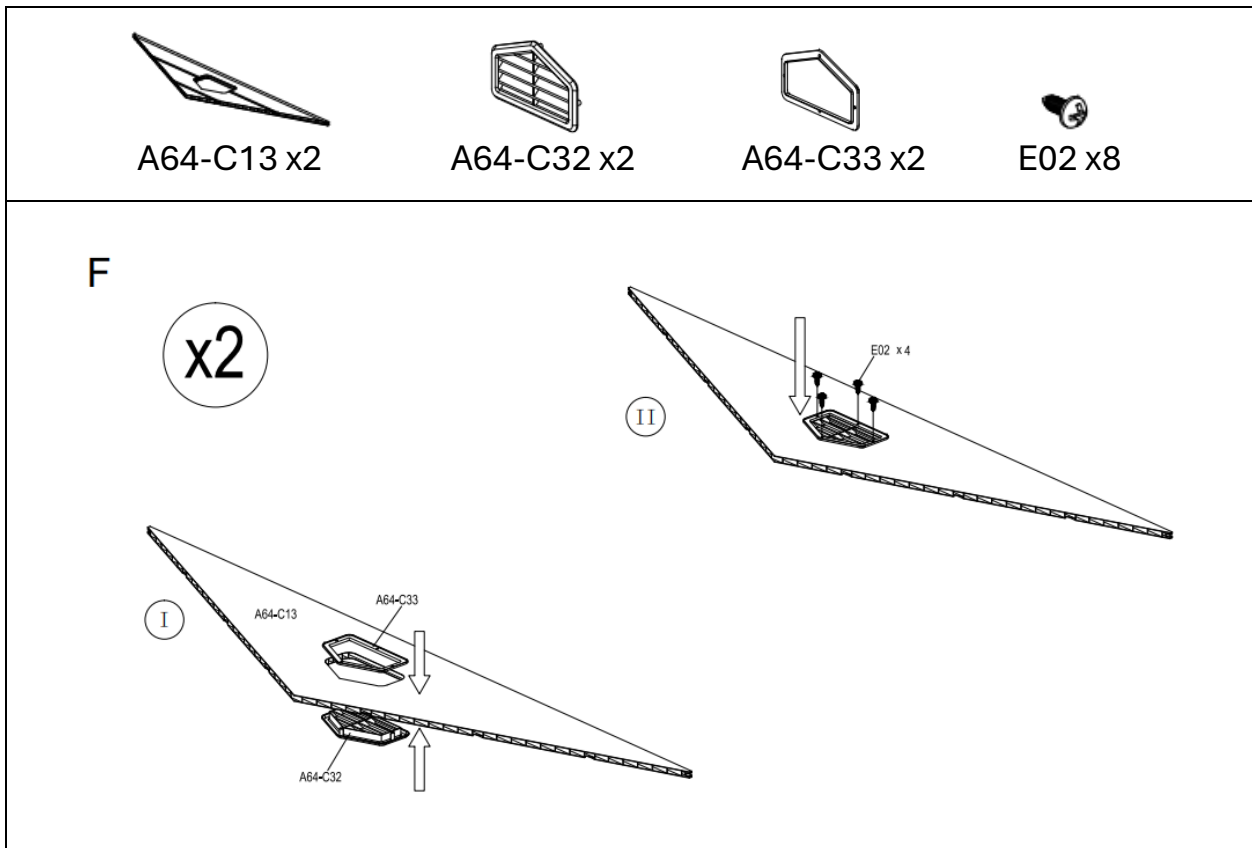

PREASSEMBLAGGIO TETTO

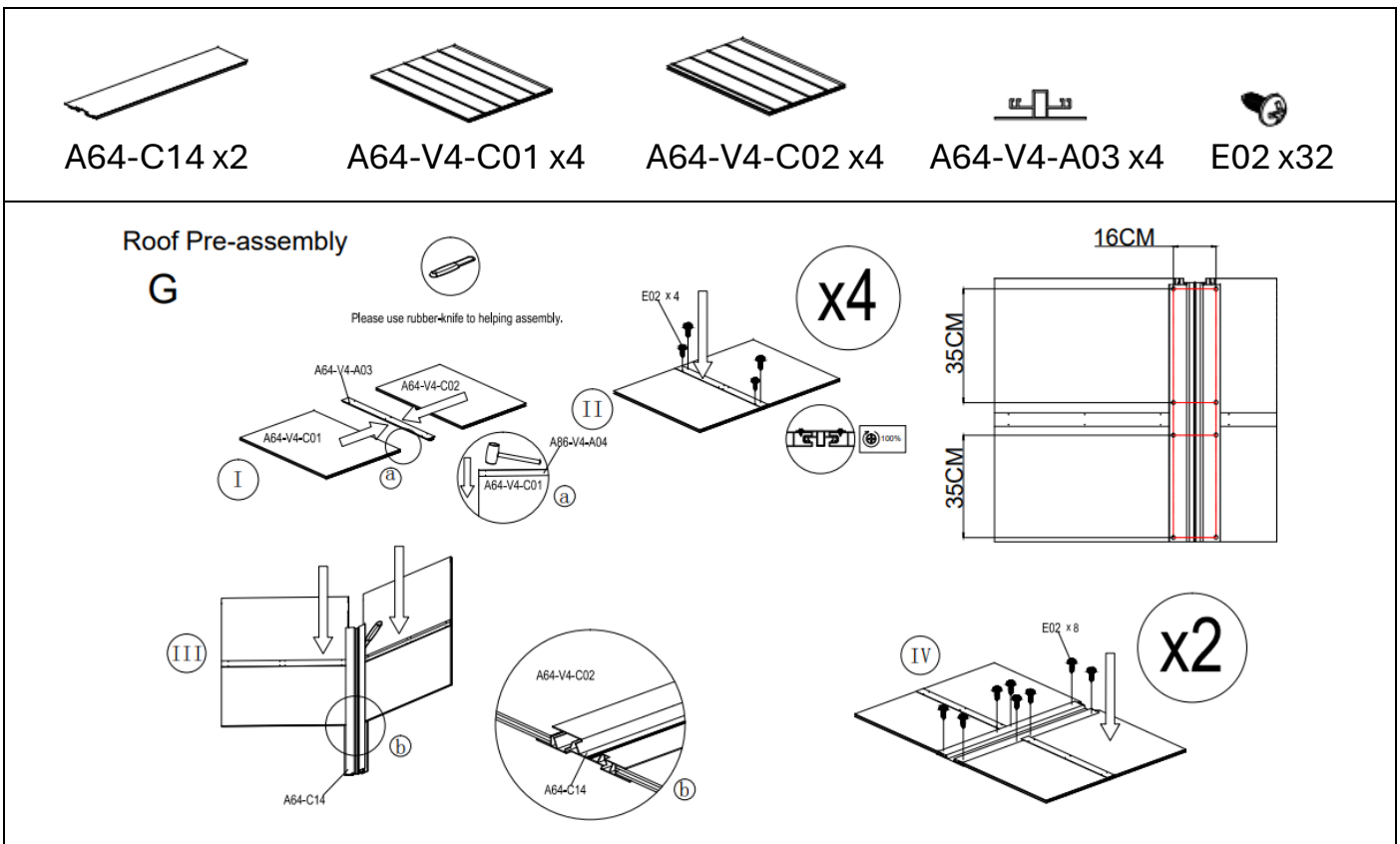

PREASSEMBLAGGIO PORTA



A34-C03

A34-C04

A64-A02



A64-A05

A64-A06 x2



A64-A15 x2



A64-C04 x3

E02 x16

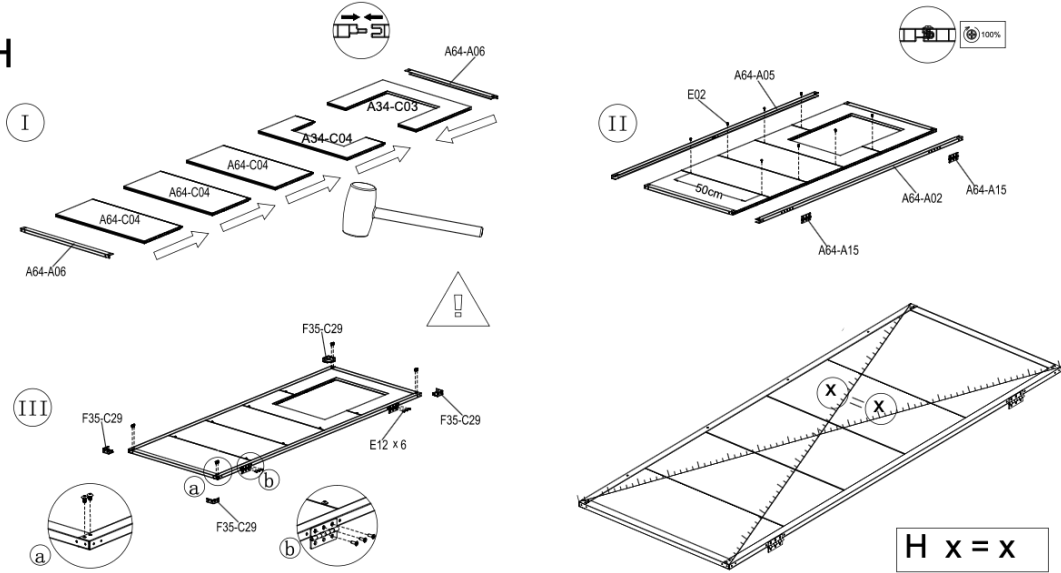
E12 x6

H



F35-C29 x4



F35-C31



F35-C32

F35-C33

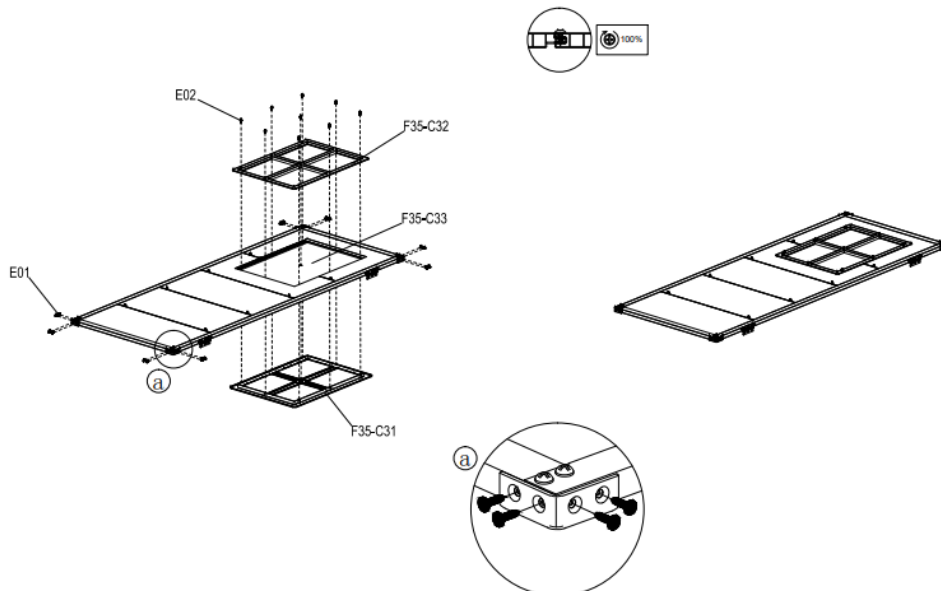
E01 x16

E02 x9

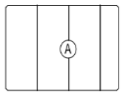



A64-C21 x4



A64-C22 x2



A64-C30 x2



F35-C27 x4



E02 x17

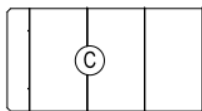
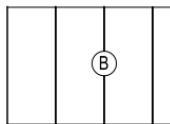
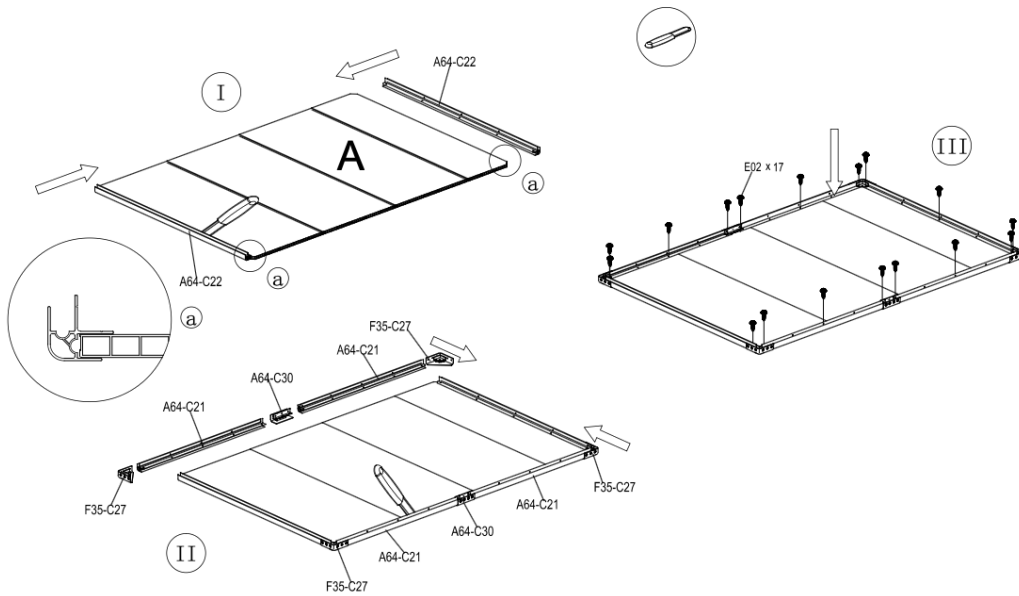

A64-C19 x1



E02 x10

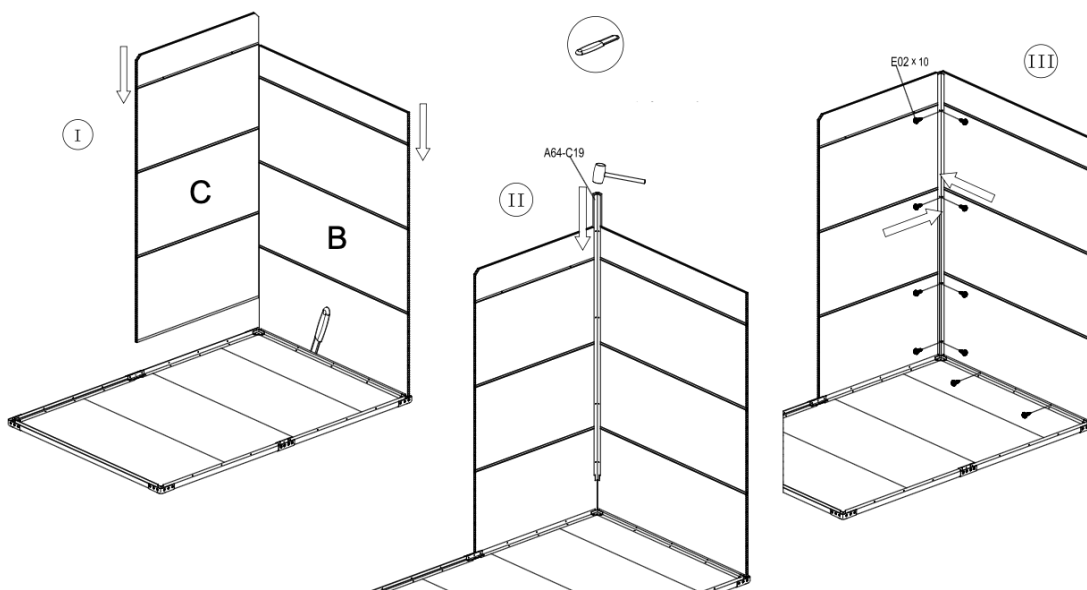

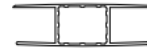
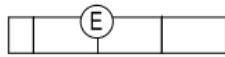
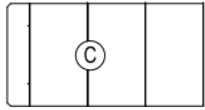

A64-C19 x1

A86-V4-C05 x1

E02 x12

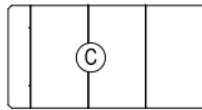
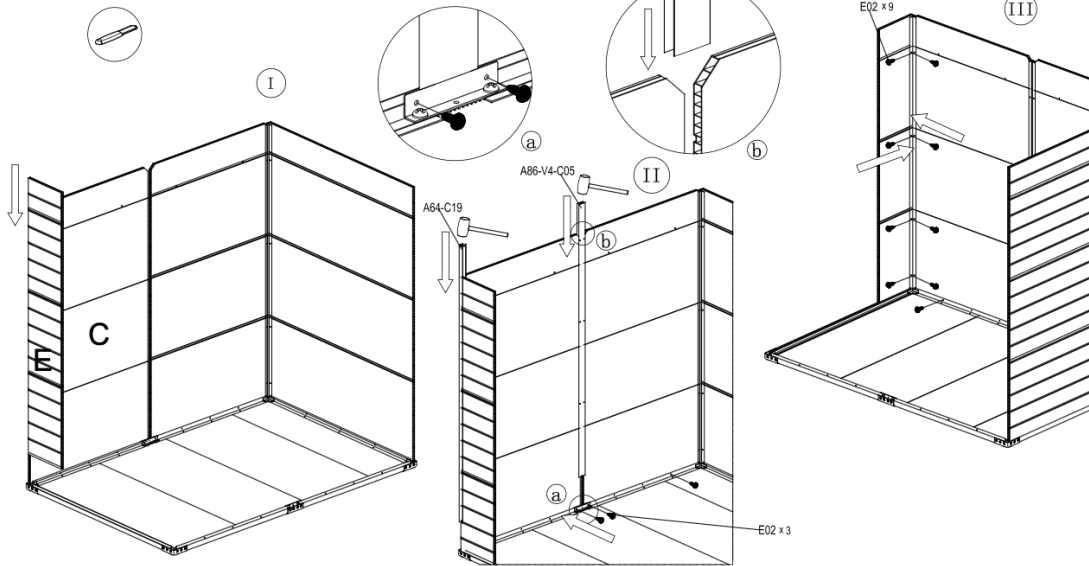

A64-C19 x1

E02 x9

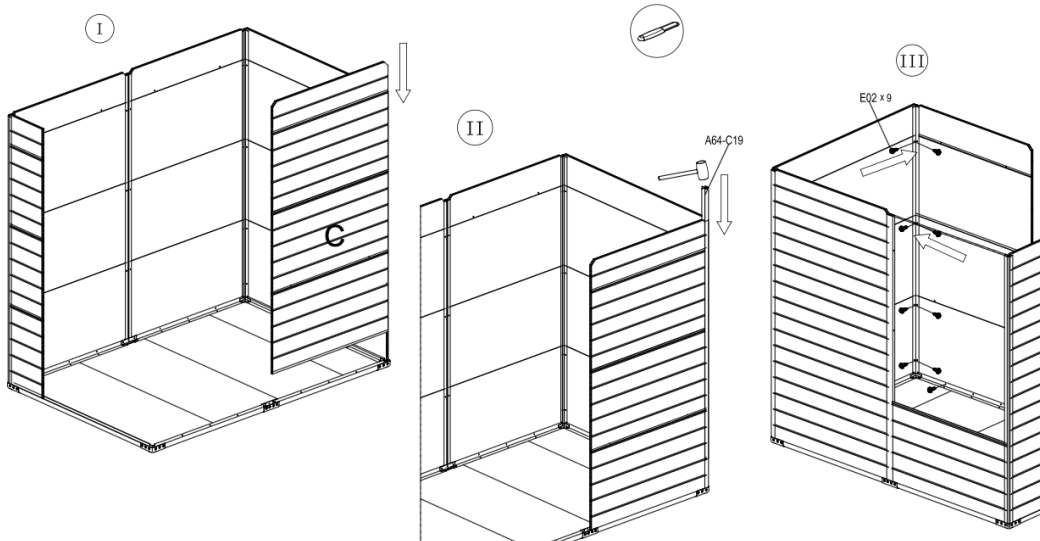

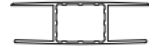
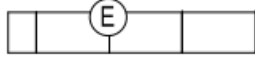
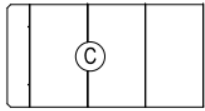

A64-C19 x1

A86-V4-C05 x1

E02 x11

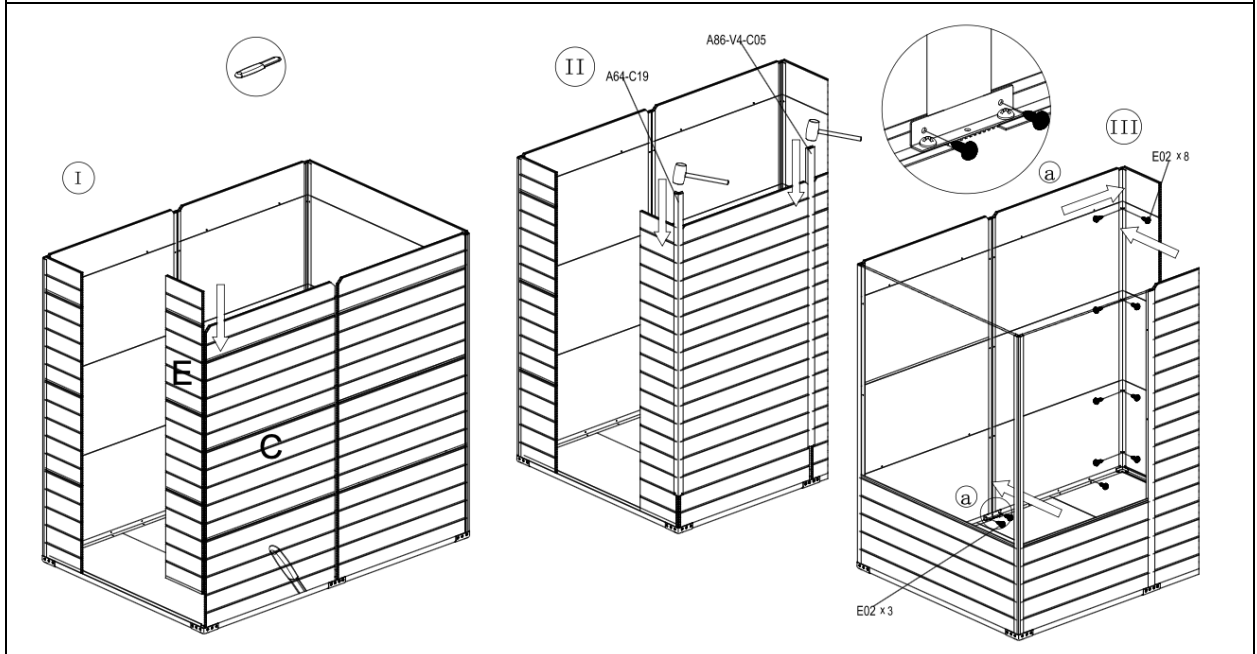

A86-V4-A07 x2



E02 x32

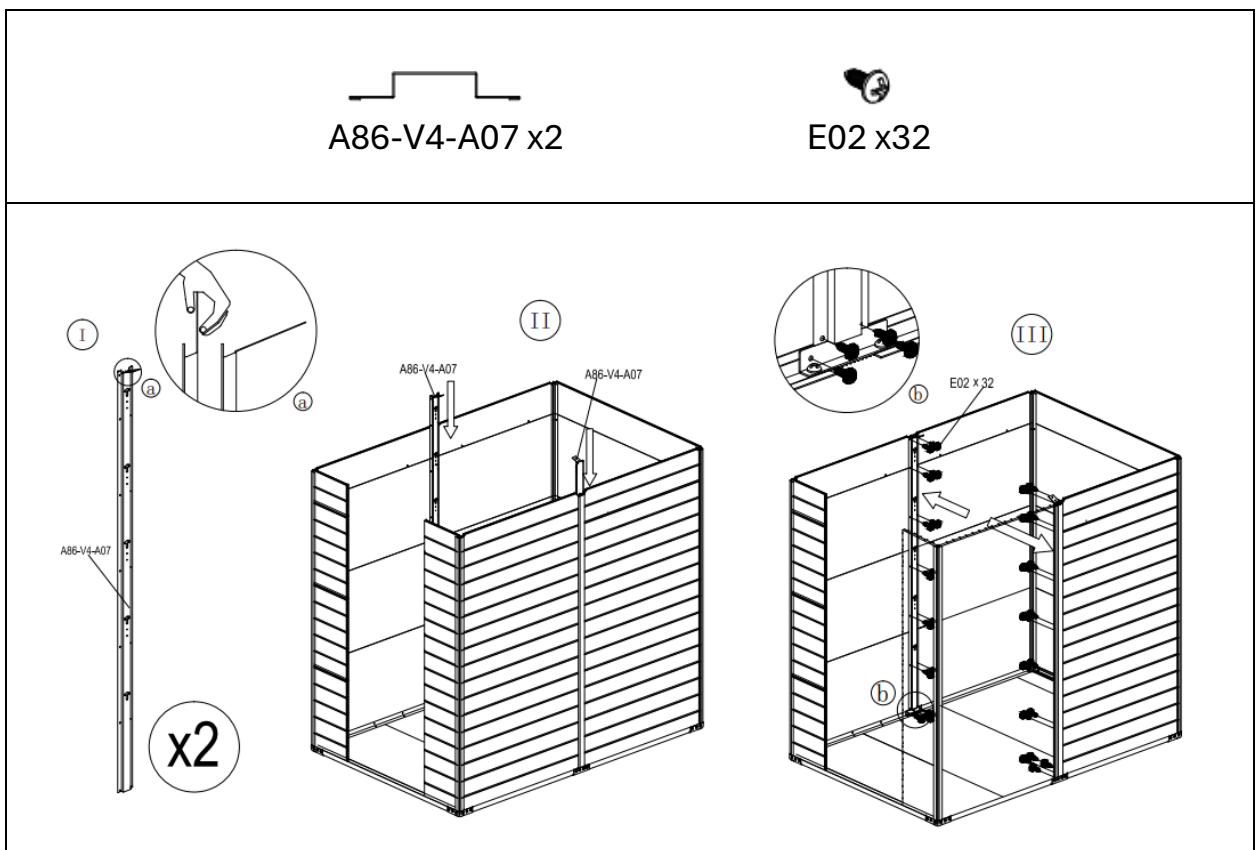



A64-V4-A02



E02 x5

I

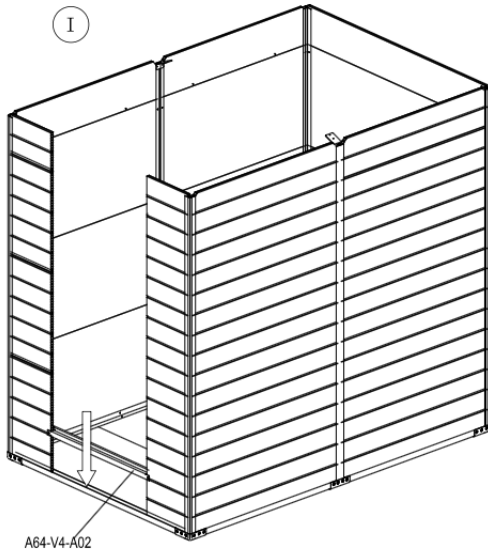

A64-V4-A02

II

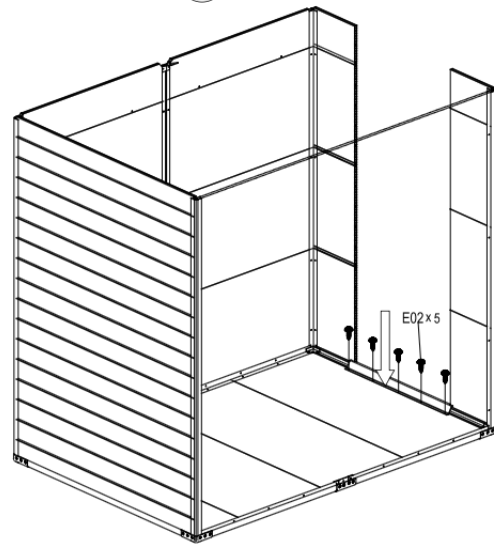

E02 x5



A64-V4-A01



A86-V4-A01



E02 x12

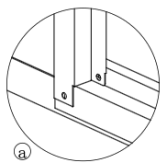

A86-V4-A01

A64-V4-A01

I

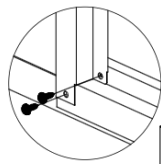
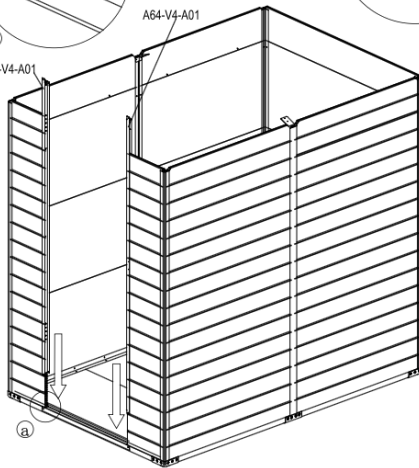

II

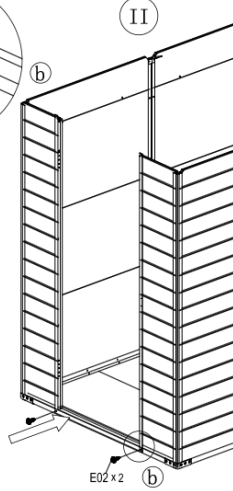

E02 x2

III

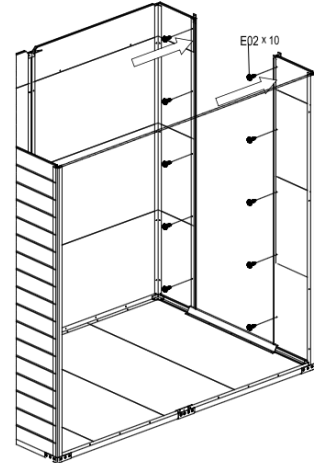

E02 x10



A64-V4-A07



E02 x8

A64-V4-A07

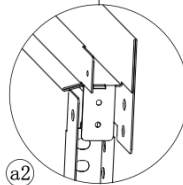
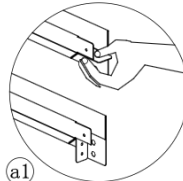
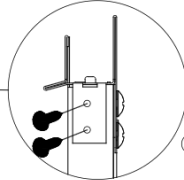
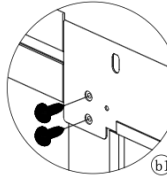
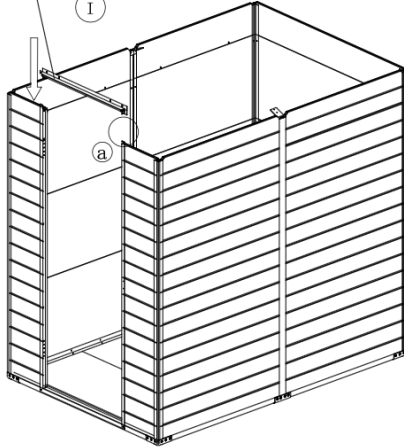

II

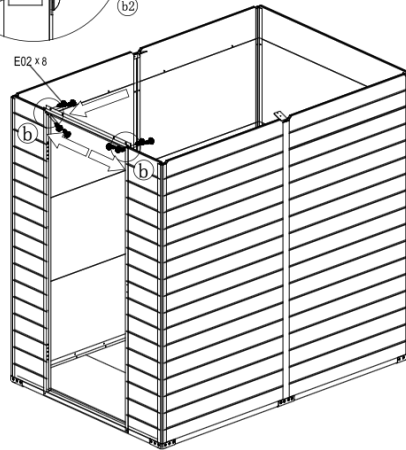

F



A64-C26



A64-C27 x2

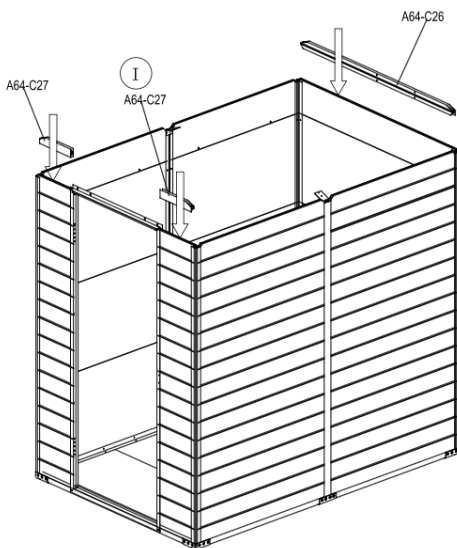

II

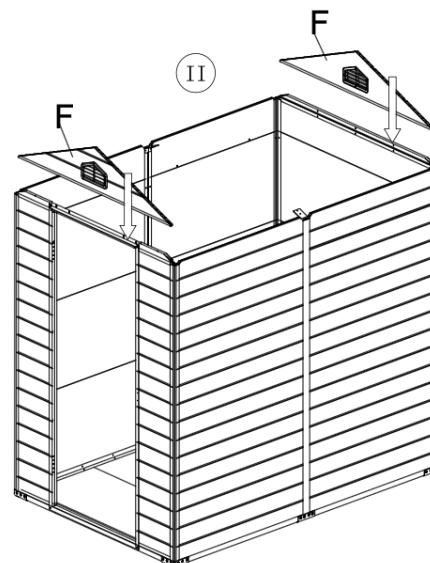



E02 x12

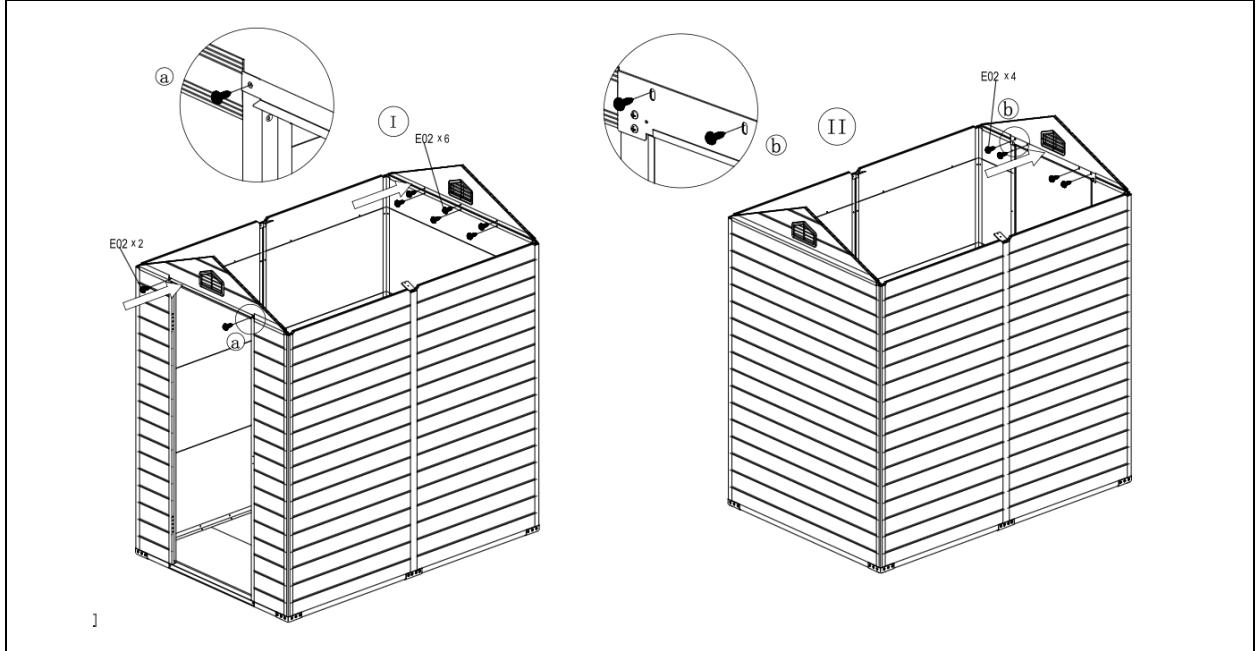

A64-C17 x4



A64-C18 x4



E02 x24

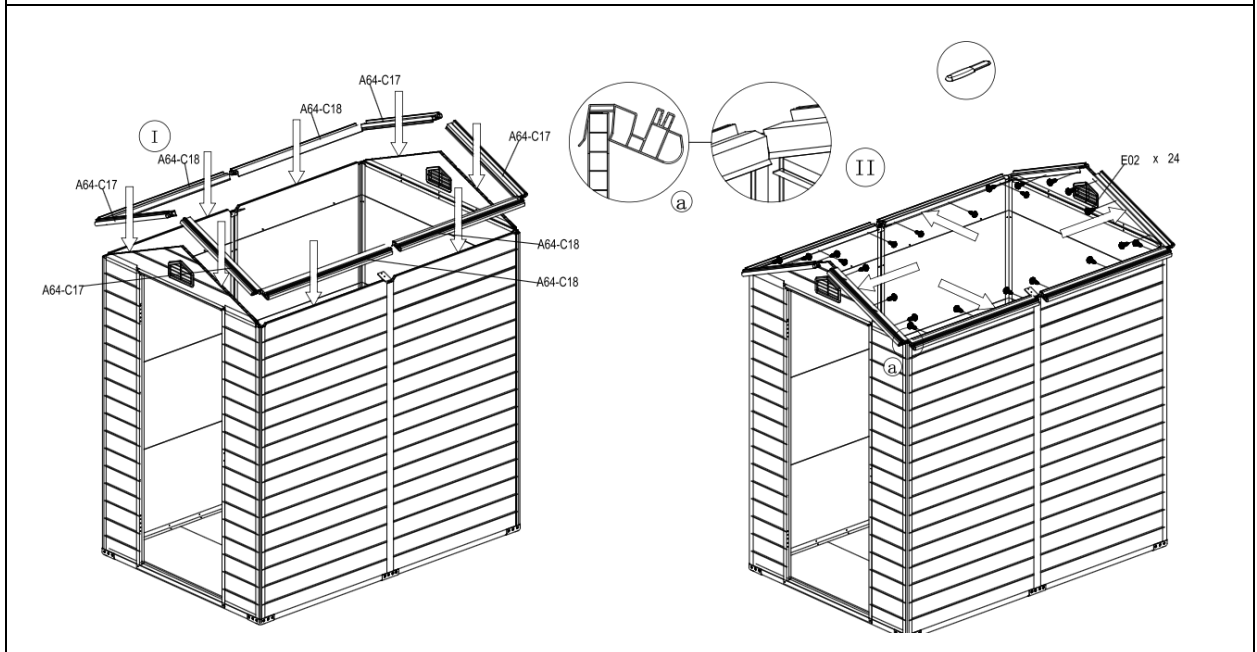

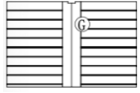

A64-V4-A04 x2

A64-V4-A05 x2

A64-C24 x2

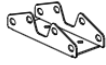

A86-V4-A06



E02 x20



E08 x4



E09 x4

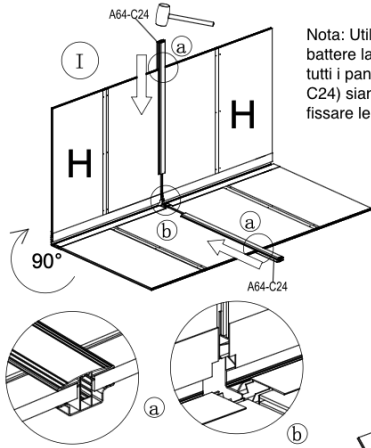

Nota: Utilizzare un martello di gomma per battere la sezione del tetto, assicurandosi che tutti i pannelli e le strutture del tetto (A64-C24) siano correttamente allineati prima di fissare le viti.

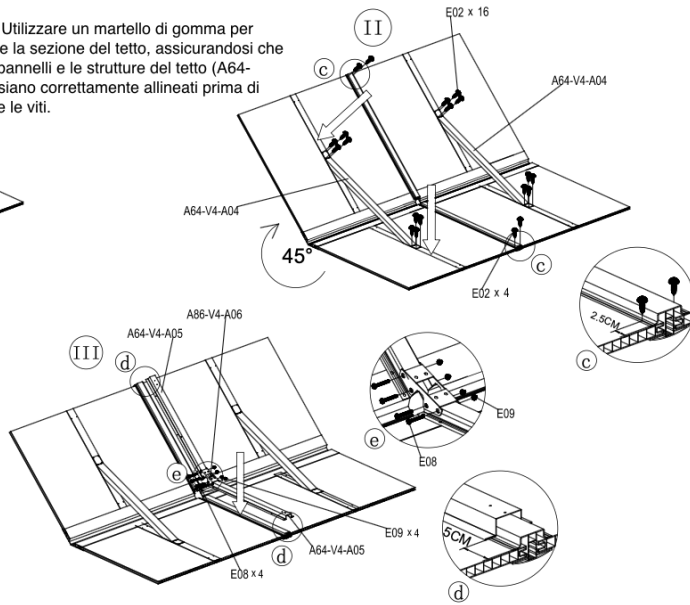

A64-C34

A64-V4-A06

E02 x20

E07 x4

E08 x2

E09 x2

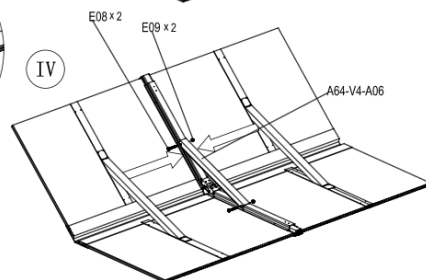
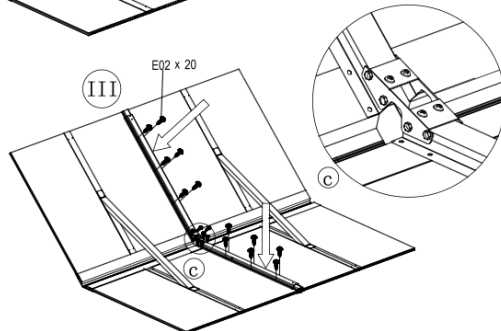
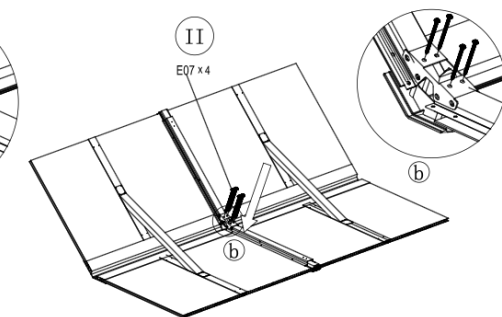
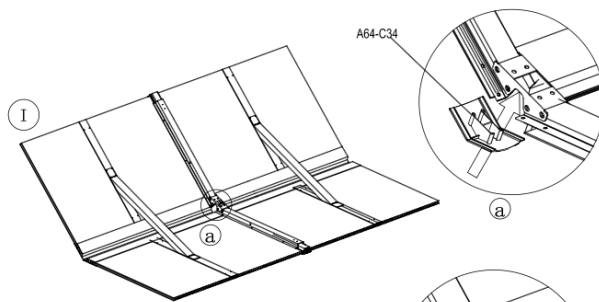

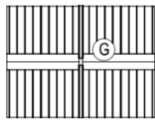

E02 x4

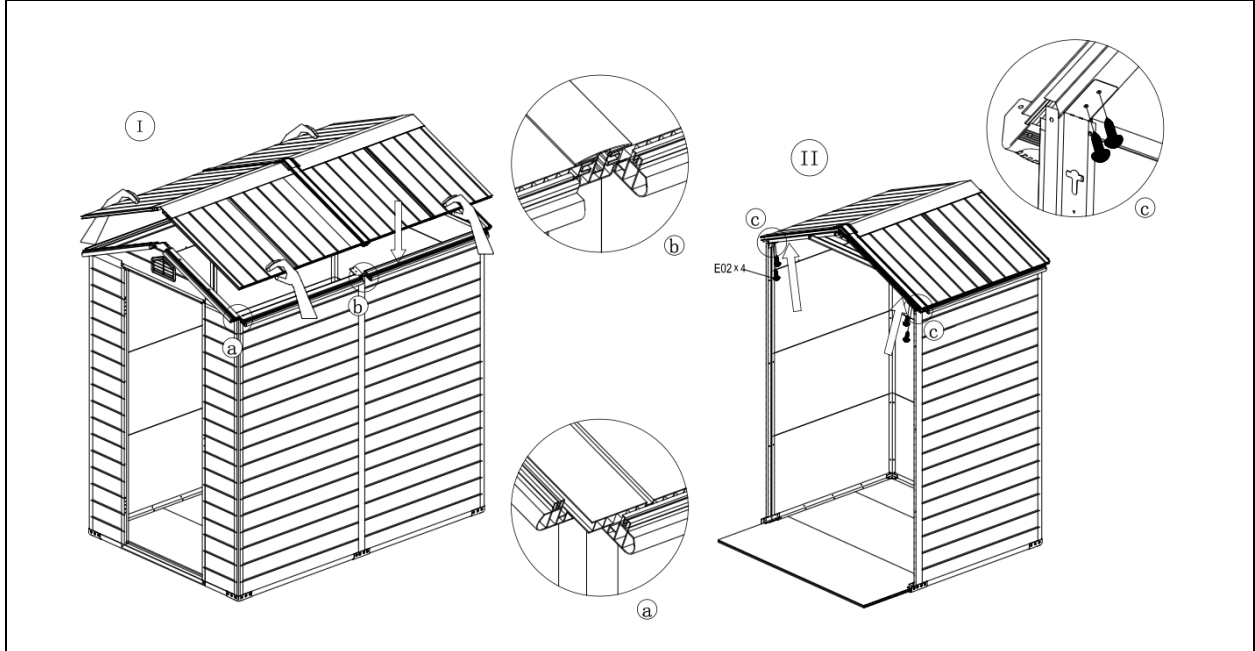

A64-C17-1 x4



A64-C18-1 x4



E02 x16

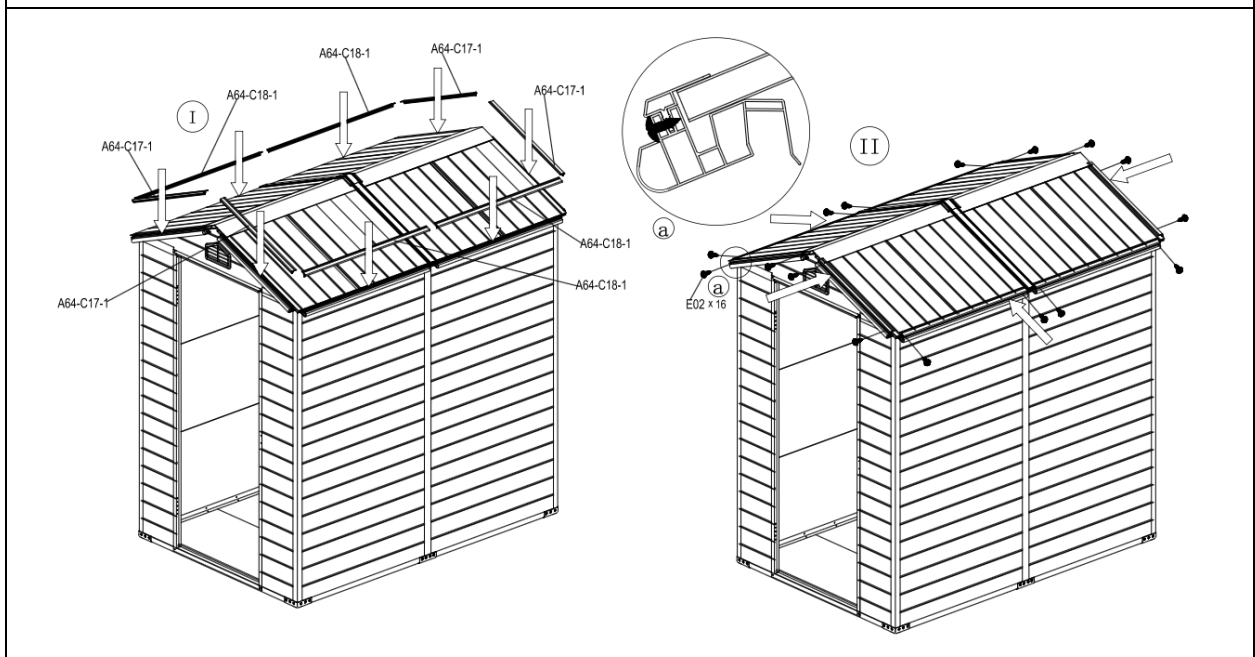



A64-C29 x2



A64-C31 x2



F35-C30 x4



E02 x32

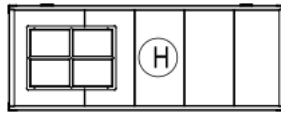
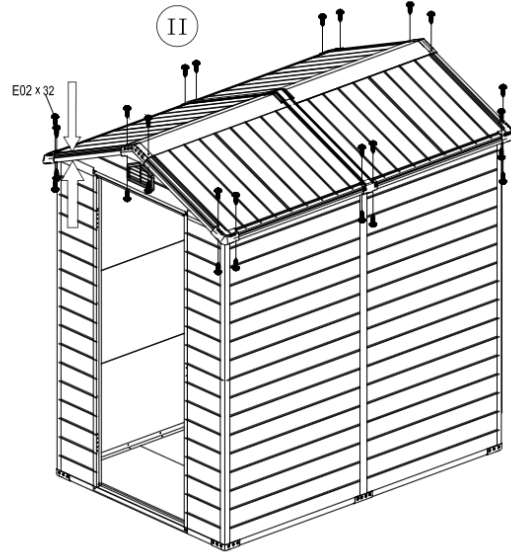
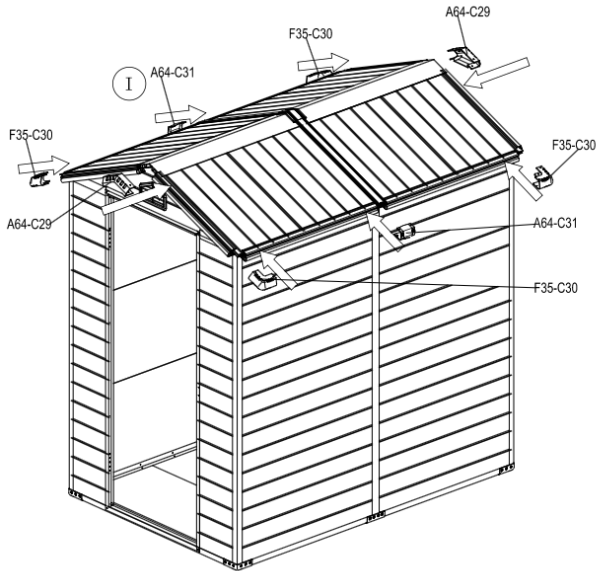

E12 x6

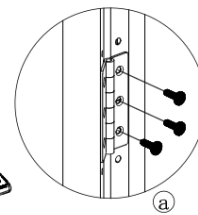
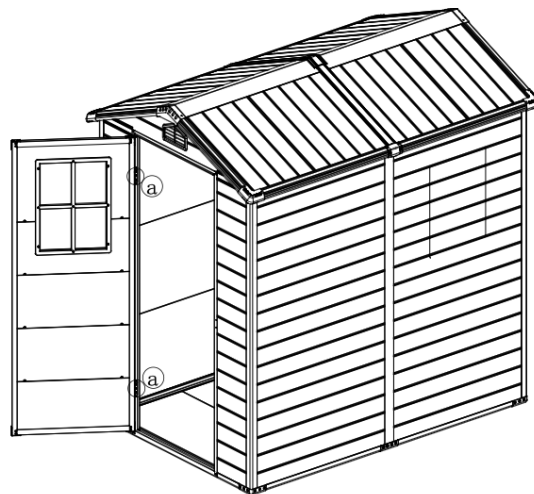



D02



E01 x4

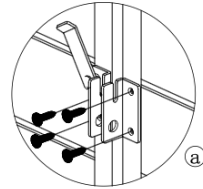
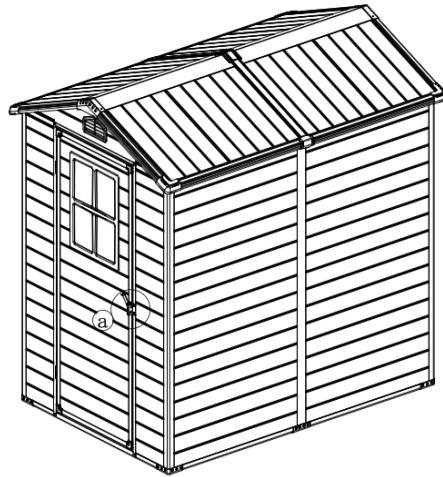

E03 x32

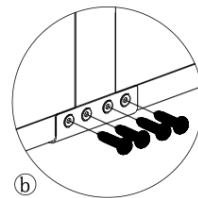
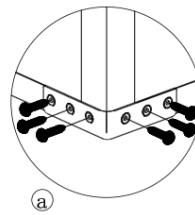
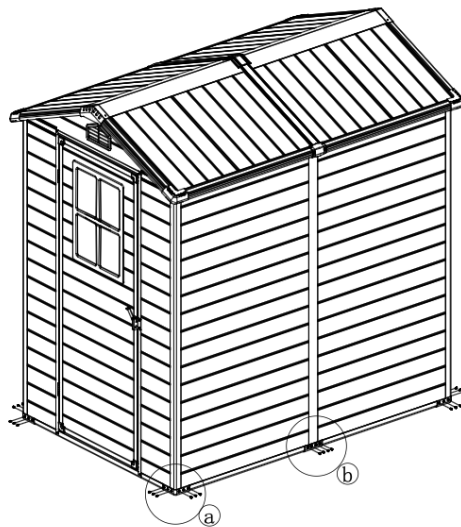



E04 x6

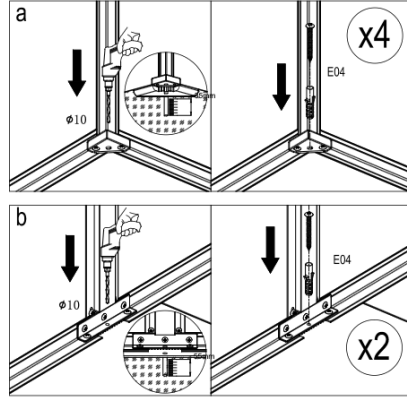
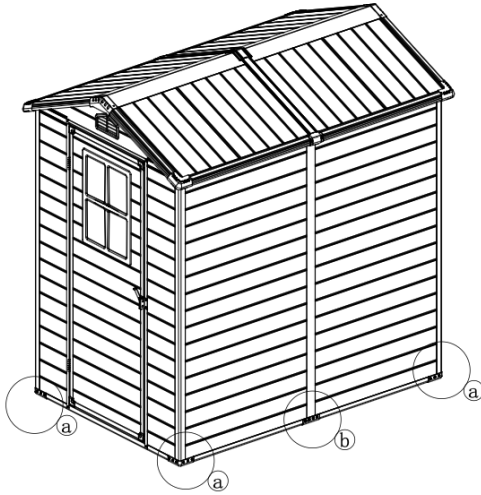

AVVERTENZE

Gentile Cliente,

grazie per aver scelto questa casetta DOMUS. Al fine di garantire la massima sicurezza, la preghiamo di attenersi alle istruzioni di montaggio indicate in questo manuale.



Conservare il presente manuale per eventuali consultazioni future

- Il presente manuale di installazione, d'uso e manutenzione è parte integrante del prodotto. Una copia del manuale è reperibile sul sito internet www.eurobrico.com.
- L'installazione deve avvenire nel rispetto del presente manuale; in caso di necessità, per chiarimenti o assistenza, contattare il servizio clienti su <https://www.eurobrico.com/it/contattaci-parla-con-noi/>

NOTA: Si informa che ci potrebbero essere delle piccole discrepanze fra il manuale ed il prodotto reale, ci scusiamo per eventuali differenze che non costituiscono comunque modifiche essenziali al prodotto, ma che sono dovute a continue migliorie e implementazioni del prodotto stesso.

La garanzia è da ritenersi valida solo se si rispettano le presenti istruzioni di montaggio.



Eurobrico S.p.A. non risponderà di danni, perdite, anomalie e malfunzionamenti che siano causati da installazione, uso, manutenzione errati o comunque difformi rispetto alle prescrizioni contenute nel presente manuale.

OBBLIGO DI UTILIZZO DI GUANTI ANTITAGLIO E DISPOSITIVI DI PROTEZIONE INDIVIDUALE DURANTE IL MONTAGGIO.

Alcune parti del prodotto possono risultare taglienti; pertanto, le stesse sono da maneggiare con cura e solo ed esclusivamente indossando specifiche protezioni. Eurobrico declina ogni responsabilità in caso di lesioni causate dal non rispetto del presente manuale.

Eurobrico Spa declina ogni responsabilità nel caso in cui l'acquirente non segua pedissequamente le istruzioni di montaggio ed i consigli e avvertenze previsti, munendosi dell'adeguata attrezzatura necessaria, il tutto come indicato nel presente manuale Domus "Istruzioni di Montaggio".

Prodotto importato da:
EUROBRICO SPA
VIA DELLA STAZIONE 100
38059 CASTEL IVANO (TN)
www.eurobrico.com
PUC: <https://rebrand.ly/SicurezzaEB>

Made in China